



TG-01M SPECIFICATION

Version V1.0

Copyright ©2021 Shenzhen Ai-Thinker Technology Co.,Ltd

Disclaimer and copyright notice

The information in this article, including the URL address for reference, is subject to change without notice.

The document is provided "as is" without any guarantee responsibility, including any guarantee for merchantability, suitability for a specific purpose, or non-infringement, and any guarantee for any proposal, specification or sample mentioned elsewhere. This document does not take any responsibility, including the responsibility for infringement of any patent rights caused by using the information in this document. This document does not grant any license for the use of intellectual property rights in estoppel or other ways, whether express or implied.

The test data obtained in the article are all obtained from Ai-Thinker's laboratory tests, and the actual results may vary slightly.

The Wi-Fi Alliance member logo is owned by the Wi-Fi Alliance.

All brand names, trademarks and registered trademarks mentioned in this article are the property of their respective owners, and it is hereby declared.

The final interpretation right belongs to Shenzhen Ai-Thinker Technology Co., Ltd.。

Note

Due to product version upgrades or other reasons, the contents of this manual may change. Shenzhen Ai-Thinker Technology Co., Ltd. reserves the right to modify the contents of this manual without any notice or prompt. This manual is only used as a guide. Shenzhen Ai-Thinker Technology Co., Ltd. makes every effort to provide accurate information in this manual. However, Shenzhen Ai-Thinker Technology Co., Ltd. does not guarantee that the contents of the manual are completely free of errors. All statements and information in this manual and suggestions do not constitute any express or implied guarantee.

CONTENT

一、	PRODUCT OVERVIEW.....	V
二、	ELECTRICAL PARAMETERS.....	错误！未定义书签。
三、	PHYSICAL DIMENSION.....	错误！未定义书签。
四、	PIN DEFINITION.....	错误！未定义书签。
五、	SCHEMATIC DIAGRAM.....	错误！未定义书签。
六、	DESIGN GUIDANCE.....	错误！未定义书签。
七、	REFLOW PROFILE.....	错误！未定义书签。
八、	PACKAGE.....	错误！未定义书签。
九、	CONTACT US.....	XVIII

一、 PRODUCT OVERVIEW

TG-01M is a module developed based on Pingtou TG7100C WiFi+BLE chip. It adopts 2.4G frequency band, WiFi 802.11b/g/n and BLE5.0 baseband/MAC design, with high performance, low cost and agile development. characteristic. It is suitable for the development of low-power and high-performance applications. It is also an integrated solution that can be directly connected to Tmall Wizard.

Its microcontroller subsystem includes a low-power 32-bit RISC CPU, cache and memory. The low-power mode can be controlled through the power management unit. At the same time, it can support up to AES 256-bit encryption engine and has a variety of security features.

In terms of software, pre-integrated standard firmware directly connected to Tmall Genie, and customizable SDK, can assist terminal products to pass Genie Magic/Genie Smart Control certification.

The chip has built-in 276 KB SRAM and 128 KB ROM. TG-01M supports a variety of low power consumption working states, which can meet the power consumption requirements of various application scenarios.

TG-01M provides a wealth of peripheral interfaces, including SDIO, SPI, I2C, IR remote, PWM, ADC, DAC, PIR and GPIO interfaces.

TG-01M has a variety of unique hardware safety mechanisms. The hardware encryption accelerator supports AES 128/192/256-bit encryption engine, SHA-1/224/256, true random number generator (TRNG), public key accelerator (PKA), etc., which can be perfectly applied to various encryption products.

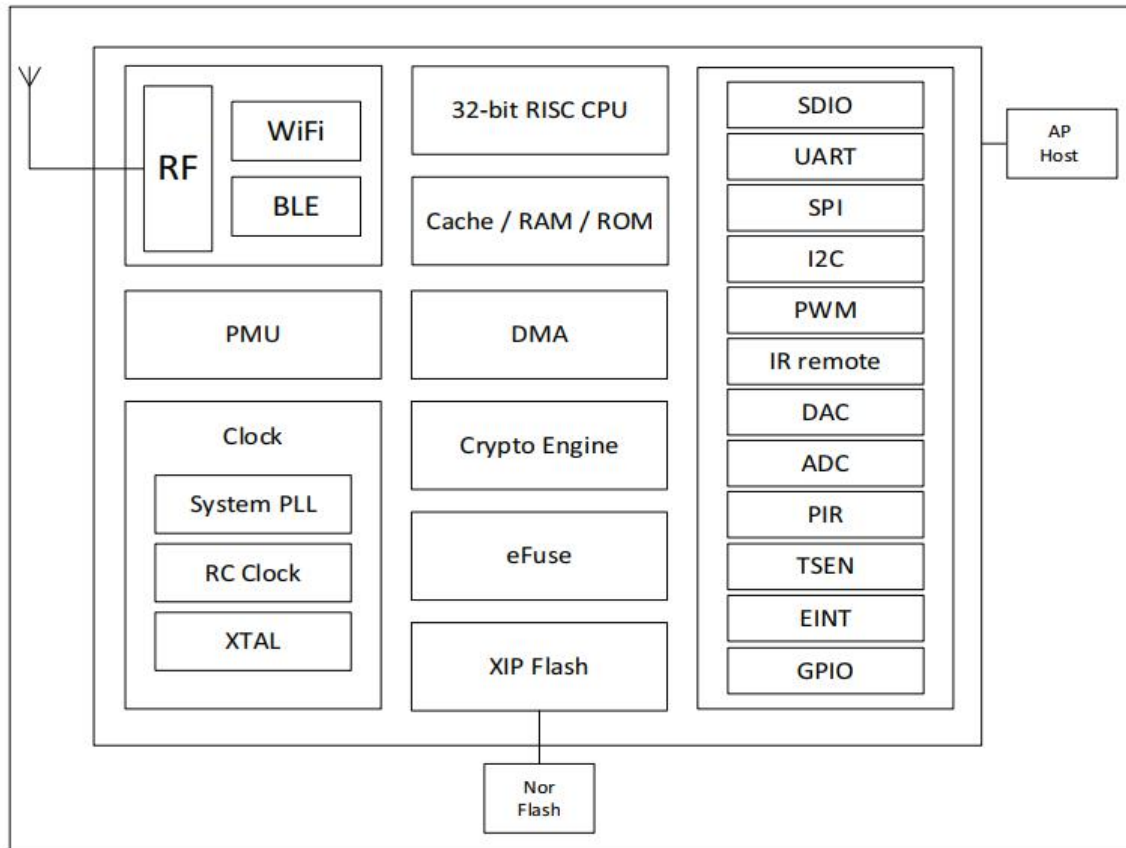

Features

- Complete 802.11b/g/n Wi-Fi + BLE SoC module;
- The TG-01M chip has a 32-bit RISC CPU with FPU (floating point unit), and the operating frequency is up to 192 MHz. Built-in 276 KB SRAM, 128 KB ROM;
- Support SDIO/SPI/UART/I2C/IR remote/PWM/ADC/DAC/PIR/GPIO interface;
- Available in DIP-18 OR SMD-15 package;
- Integrated Wi-Fi MAC/BB/RF/PA/LNA;
- Support multiple sleep modes, deep sleep current is less than 30uA;
- Support serial port local upgrade and remote firmware upgrade (FOTA) ;
- General AT commands can be used quickly;
- Support secondary development, integrated Linux development environment;

Main parameters

List 1 Main parameter description

Model	TG-01M
Packaging	DIP-18 OR SMD-15
Size	18.0*18.0*2.8(±0.2)MM
Antenna	PCB antenna
Spectrum range	2400 ~ 2483.5MHz
Working temperature	-40 °C ~ 85 °C
Storage environment	-40 °C ~ 125 °C , < 90%RH
Power supply range	Voltage 3.0V ~ 3.6V, current >500mA
Interface supported	SDIO/SPI/UART/I2C/IR remote/PWM/ADC/DAC/PIR/GPIO
Serial port rate	Support 110 ~ 4608000 bps , 115200 bps by default
Safety	AES/SHA/PKA
SPI Flash	2MB

二、 ELECTRICAL PARAMETERS

The TG-01M module is an electrostatic sensitive device, and special precautions must be taken when handling it.



Electrical characteristics

Parameter	Condition	Min	Typical	Max	Unit	
Voltage	VDD	3.0	3.3	3.6	V	
I/O	V_{IL}/V_{IH}	-	-0.3/0.75VIO	-	0.25VIO/3.6	V
	V_{OL}/V_{OH}	-	N/0.8VIO	-	0.1VIO/N	V
	I_{MAX}	-	-	-	12	mA

RF performance

Description	Typical	Unit
Working frequency	2400 - 2483.5	MHz
Output power		
11n mode HT20, PA output power is	15±2	dBm
In 11g mode, the PA output power is	16±2	dBm

In 11b mode, the PA output power is	18±2	dBm
Receiving sensitivity		
CCK, 1 Mbps	≤ -97	dBm
CCK, 11 Mbps	≤ -88	dBm
6 Mbps (1/2 BPSK)	≤ -92	dBm
54 Mbps (3/4 64-QAM)	≤ -75	dBm
HT20 (MCS7)	≤ -72	dBm

Power consumption

The following power consumption data is based on a 3.3V power supply, an ambient temperature of 25°C, and measured using an internal voltage regulator.

- All measurements are done at the antenna interface without SAW filter.
- All emission data is based on 90% duty cycle, measured in continuous emission mode.

Mode	Min	Typical	Max	Unit
Transmit 802.11b, CCK 1Mbps, POUT=+21dBm	-	180	320	mA
Transmit 802.11g, OFDM 54Mbps, POUT =+18dBm	-	145	250	mA
Transmit 802.11n, MCS7, POUT =+17dBm	-	135	250	mA
Receive 802.11b, packet length 1024 bytes, -80dBm	-	40	-	mA
Receive 802.11g, packet length 1024 bytes, -70dBm	-	40	-	mA
Receive 802.11n, packet length 1024 bytes, -65dBm	-	40	-	mA
Deep-Sleep ^③	-	30	-	μA
Power Off	-	1	-	μA

三、 PHYSICAL DIMENSION

Appearance of TG-01M

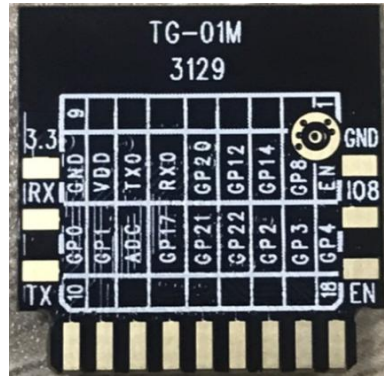

(Pictures and silk screens are for reference only, the actual product shall prevail)

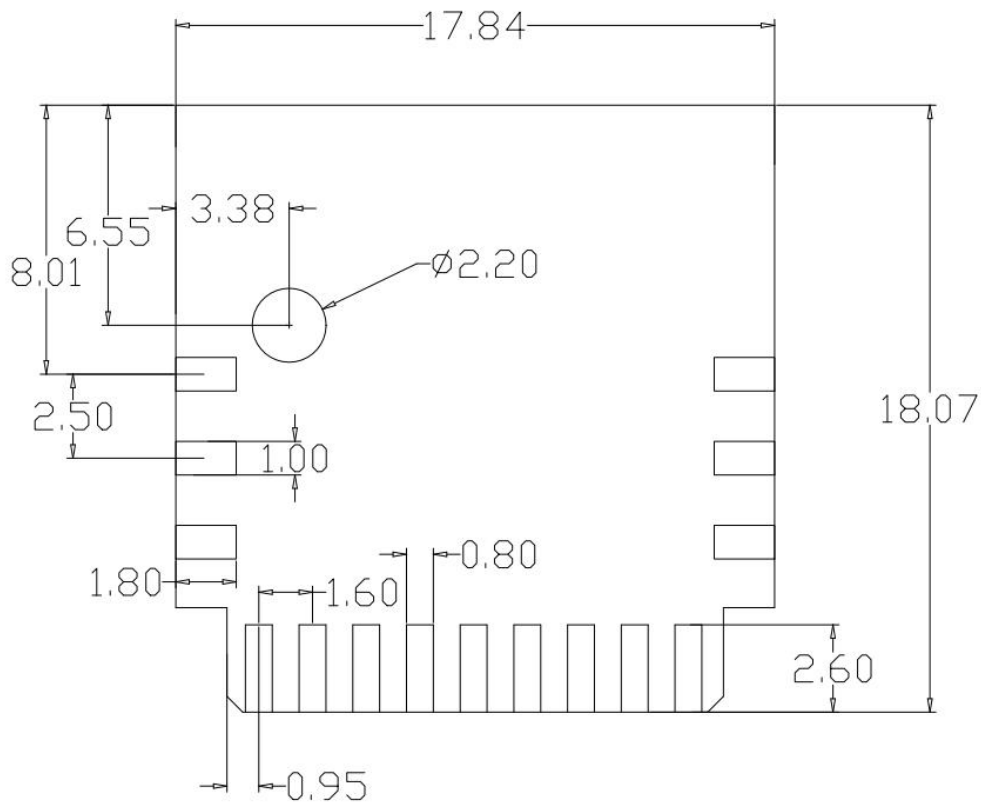

四、 PIN DEFINITION

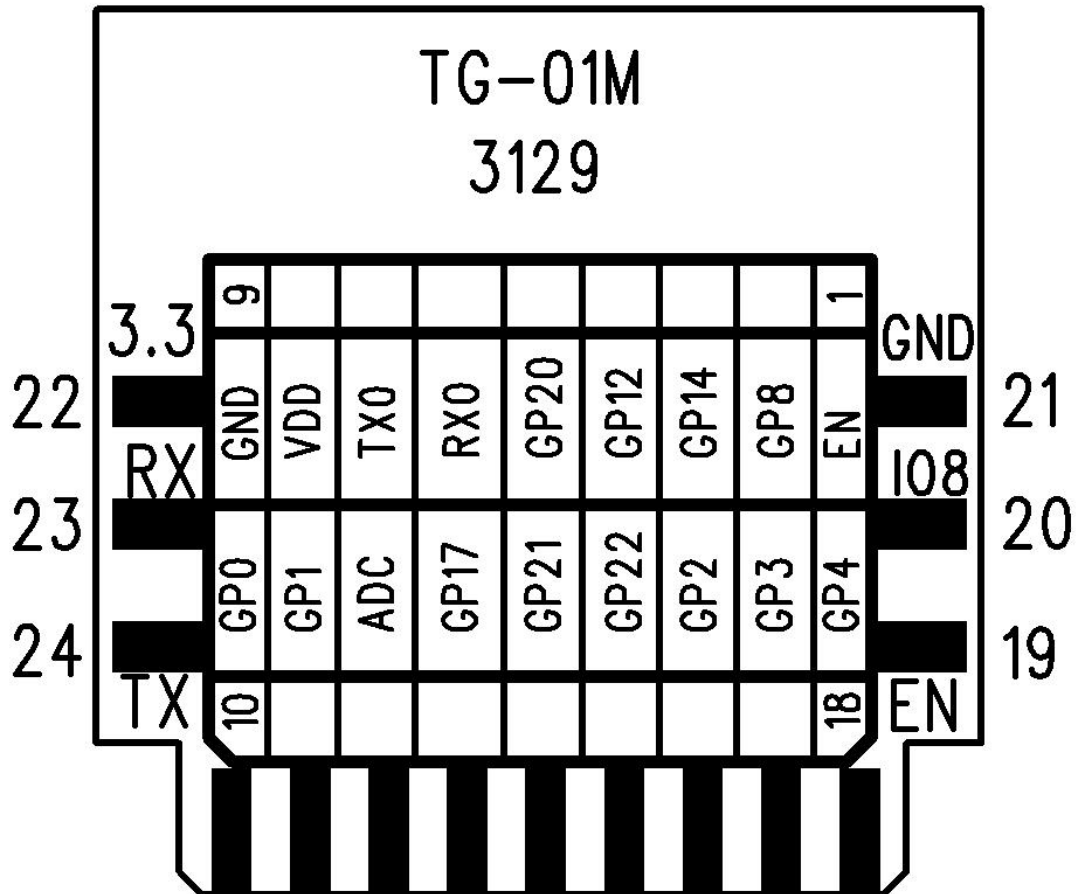

(图片及丝印仅供参考，以实物为准)

The TG-01M module has a total of 18 DIP interfaces and 15 SMD interfaces. As shown in the pin diagram, the pin function definition table is the interface definition.

TG-01M (DIP-18 & DIP-15) Pin diagram

List Pin function definition

Pin	Name	Function description
1	EN/RST	Chip enable
2	IO8	SPI,I2C,UART,PWM,AUXADC,GPIO
3	IO14	SPI,I2C,UART,PWM,AUXADC,GPIO
4	IO12	SPI,I2C,UART,PWM,AUXADC,GPIO

5	IO20	SFLASH,SPI,I2C,UART,PWM,GPIO
6	RXD	SPI,I2C,UART,PWM,AUXADC,GPIO
7	TXD	SPI,I2C,UART,PWM,GPIO
8	VDD	VDD
9	GND	GND
10	IO0	SDIO,SFLASH,SPI,I2C,UART,PWM,GPIO
11	IO1	SDIO,SFLASH,SPI,I2C,UART,PWM,GPIO
12	IO11	SPI,I2C,UART,PWM,AUXADC,GPIO
13	IO17	SFLASH,SPI,I2C,UART,PWM,GPIO
14	IO21	SFLASH,SPI,I2C,UART,PWM,GPIO
15	IO22	SFLASH,SPI,I2C,UART,PWM,GPIO
16	IO2	SDIO,SFLASH,SPI,I2C,UART,PWM,GPIO
17	IO3	SDIO,SPI,I2C,UART,PWM,GPIO
18	IO4	SDIO,SPI,I2C,UART,PWM,GPIO
19	EN/RST	Chip enable
20	IO8	SPI,I2C,UART,PWM,AUXADC,GPIO
21	GND	GND
22	VDD	VDD
23	RXD	SPI,I2C,UART,PWM,AUXADC,GPIO
24	TXD	SPI,I2C,UART,PWM,GPIO

List Module startup mode description

System startup mode			
Pin	Default	SPI boot mode	Download start mode
EN/RST	pull up	pull up	pull up
IO8	pull down	pull down	pull up

五、SCHEMATIC DIAGRAM

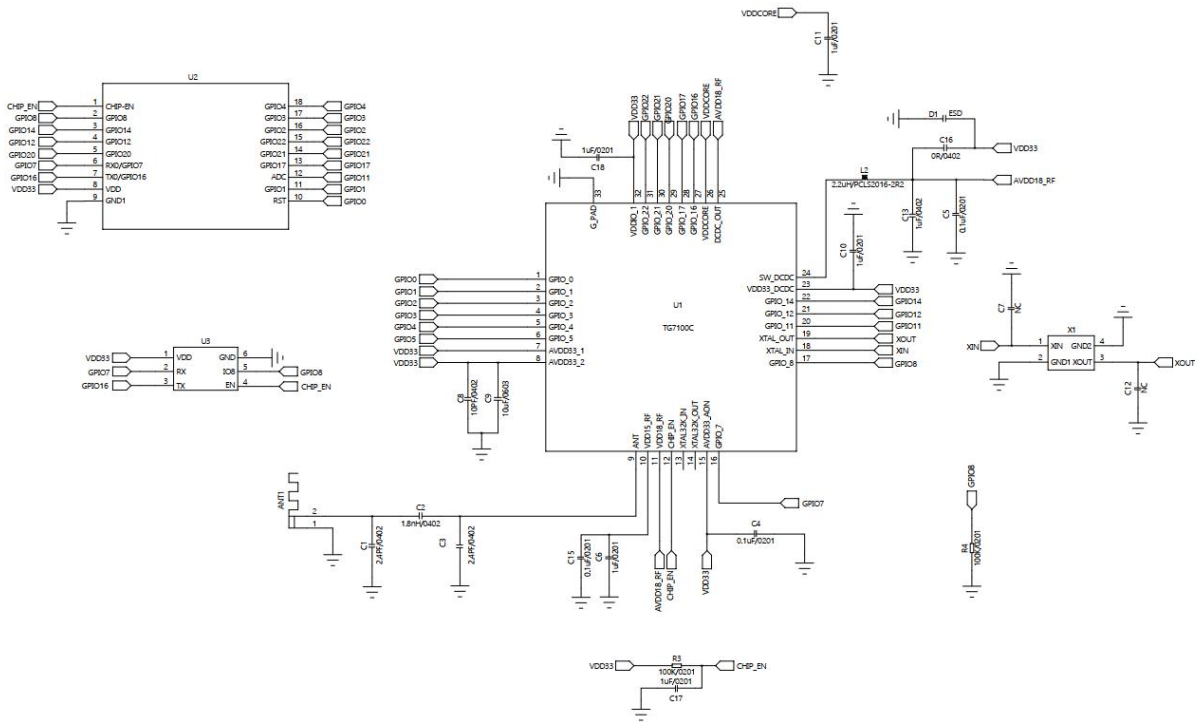

六、 DESIGN GUIDANCE

1, Application circuit

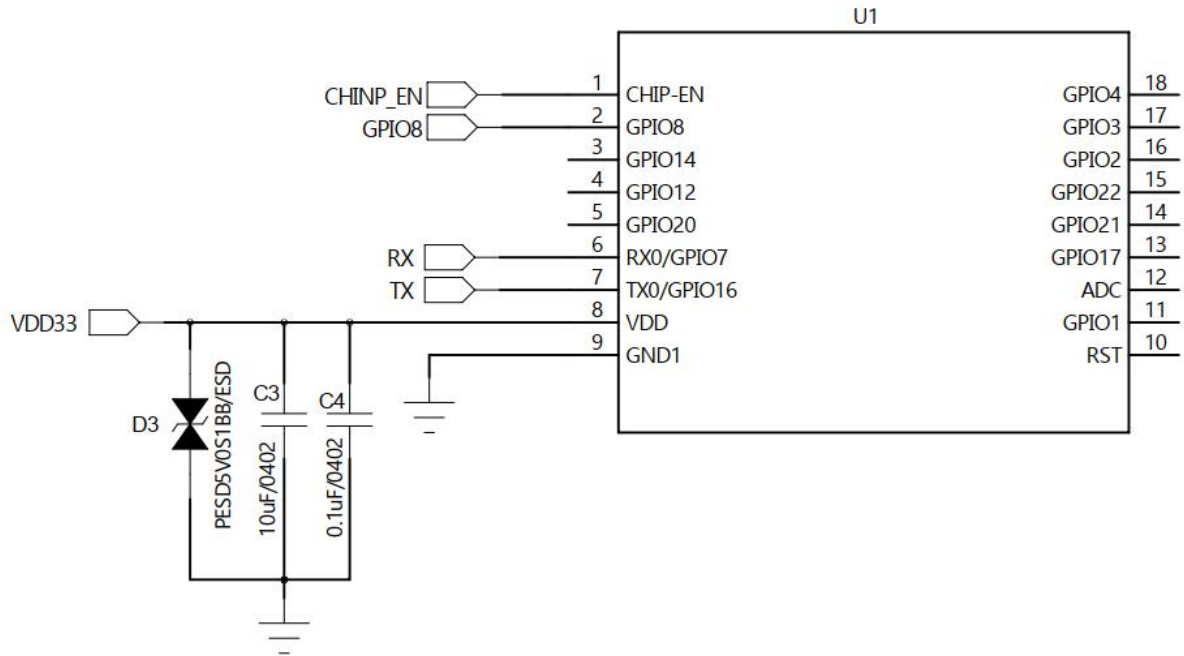

2, Recommended module package design size

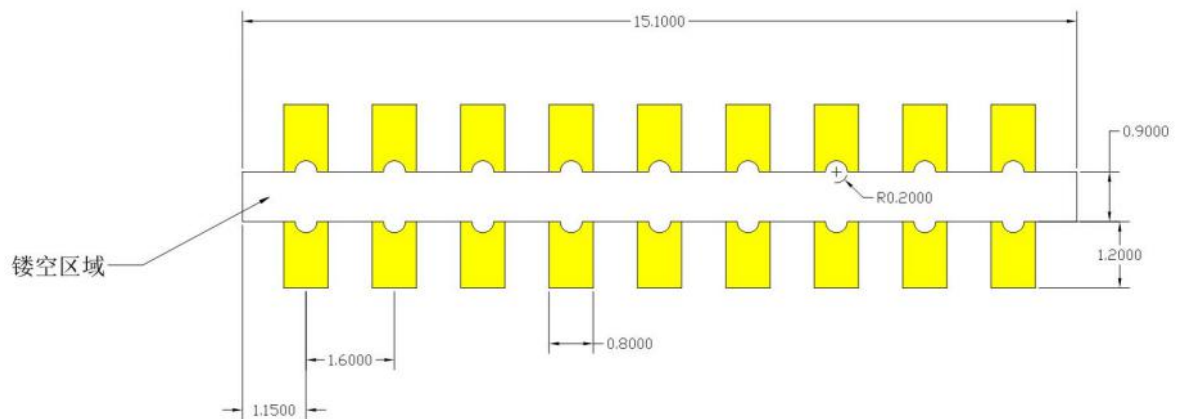

3, Antenna layout requirements

(1)、For the installation position on the motherboard, the following two methods are recommended:

Solution 1: Put the module on the edge of the motherboard, and the antenna area extends out of the edge of the motherboard.

Solution 2: Put the module on the edge of the motherboard, and hollow out an area at the antenna position on the edge of the motherboard.

(2)、In order to meet the performance of the onboard antenna, it is forbidden to place metal parts around the antenna, away from high-frequency components.

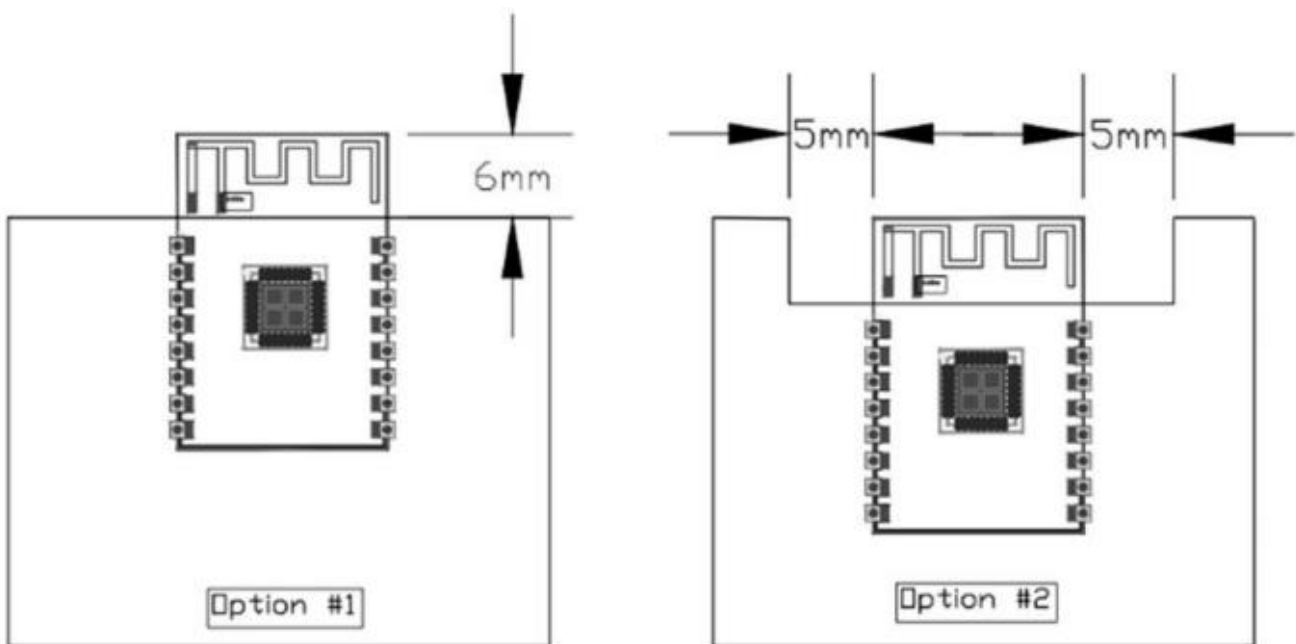

4、Power supply

(1)、Recommend 3.3V voltage, peak current above 500mA.

(2)、It is recommended to use LDO for power supply; if DC-DC is used, the ripple is recommended to be controlled within 30mV.

(3)、It is recommended to reserve the position of the dynamic response capacitor for the DC-DC power supply circuit, which can optimize the output ripple when the load changes greatly.

(4)、It is recommended to add ESD devices to the 3.3V power interface.

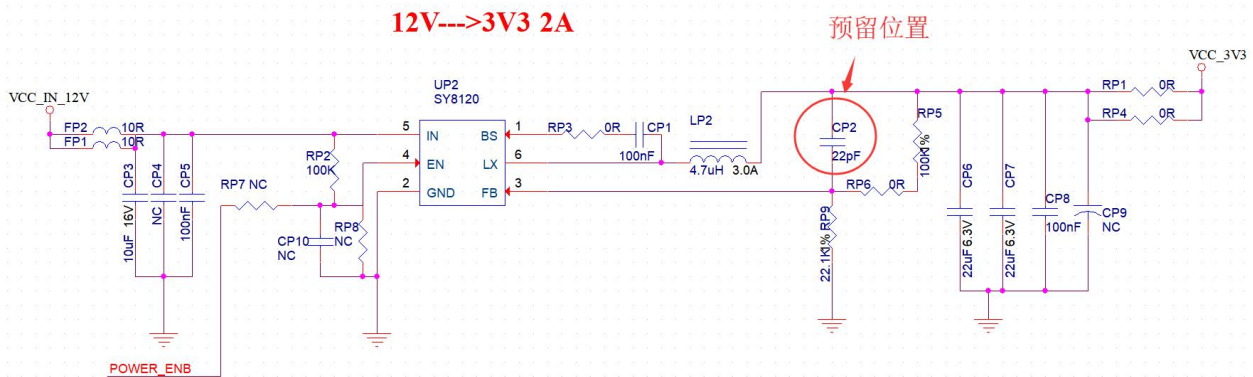

5, Use of GPIO port

- (1)、There are some GPIO ports on the periphery of the module. If you need to use it, it is recommended to connect a 10-100 ohm resistor in series with the IO port. This can suppress overshoot and make the levels on both sides more stable. Good for EMI and ESD.
- (2)、For the pull-up and pull-down of special IO ports, please refer to the instructions in the specification, which will affect the startup configuration of the module.
- (3)、The IO port of the module is 3.3V. If the main control and the IO level of the module do not match, a level conversion circuit needs to be added.
- (4)、If the IO port is directly connected to a peripheral interface or terminal such as a header, it is recommended to reserve an ESD device near the terminal on the IO trace.

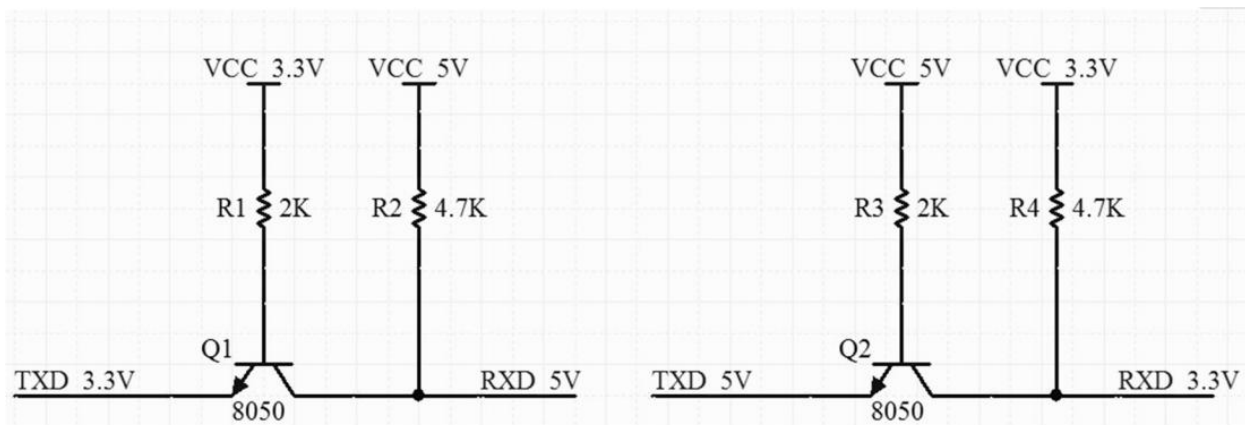

Pic Level conversion circuit

七、 REFLOW PROFILE

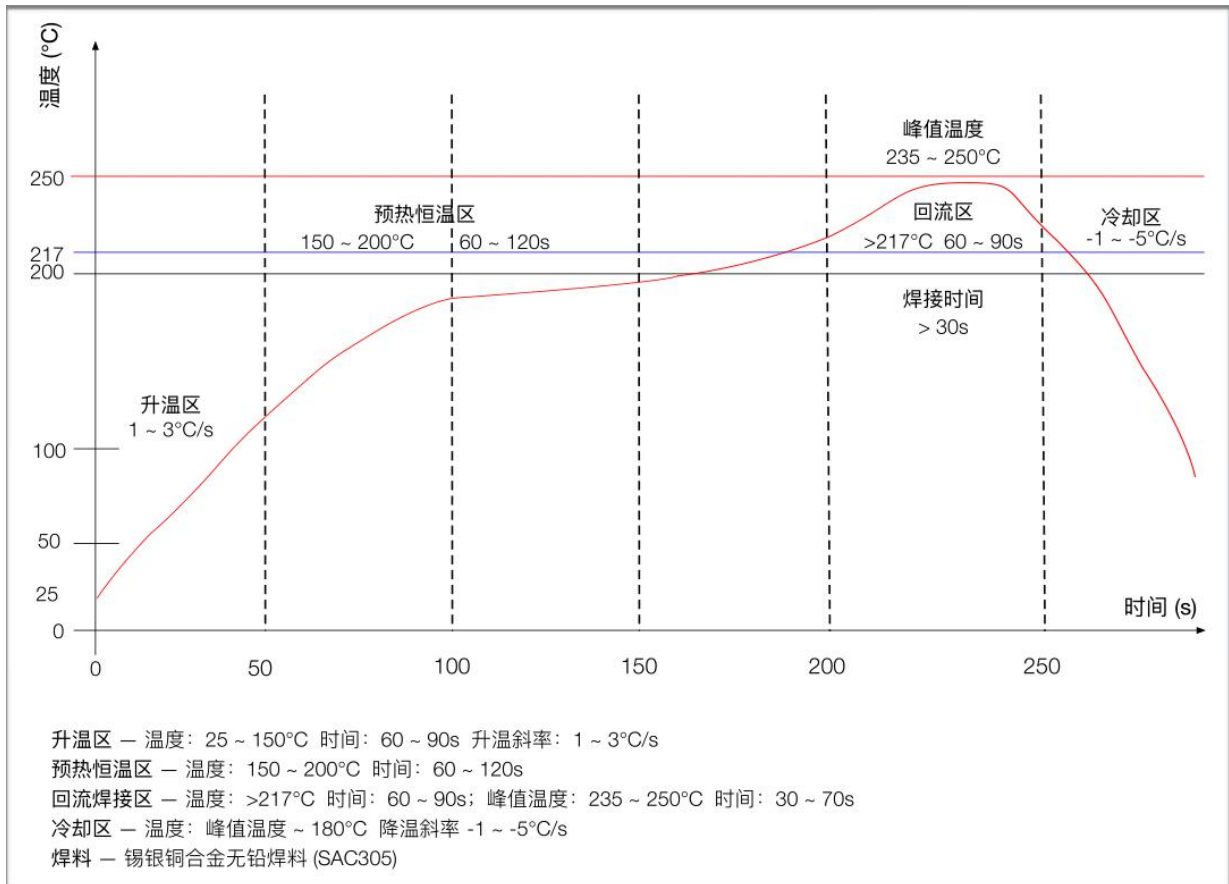

八、 PACKAGE

As shown below, the default packaging of TG-01M is taping



九、 CONTACT US

Website: <https://www.ai-thinker.com>

Development DOCS: <https://docs.ai-thinker.com>

Official forum: <http://bbs.ai-thinker.com>

Buy a sample: <https://ai-thinker.en.alibaba.com/>

Business: sales@aithinker.com

Support: support@aithinker.com

Address: 408-410, Block C, Huafeng Smart Innovation Port, Gushu 2nd Road, Xixiang, Baoan District,
Shenzhen

Tel: 0755-29162996

