

RAK5205 WisTrio LPWAN Tracker Datasheet

Overview

Description

The **RAK5205 WisTrio LPWAN Tracker board** is built on the Semtech SX1276 chip, with the STM32L1 MCU at its core. It is a feature-packed sensor board with LoRa connectivity and built-in GPS. It provides various interfaces for easy application development.

This is the ideal LPWAN tracker board with a built-in sensor available in the market. It is best used as a quick prototyping module for Internet-of-Things and LoRaWAN Network integration. Its perfect use cases for IoT applications include asset tracking, smart vehicle management, and location-based services.

Features

- Compatible with **96Boards IoT Edition Specification**
- With **SX1276 LoRa** long-range and **Ublox Max 7Q GPS** modems which allow to enable the GPS low power mode
- Integrated the ultra-low-power microcontroller **ARM Cortex-M3 STM32L1**
- Built-in environmental **sensor BME680** (gas, pressure, humidity, temperature) and **3-axis MEMS sensor LIS3DH** (accelerometer)
- **SMA/iPEX antenna** optional for LoRa and GPS
- Supports latest LoRaWAN 1.0.2 protocol, activation by OTAA/ABP
- Supports programmable bit rate up to 300 kbps
- Supports rechargeable battery through micro USB or 5 V solar charging ports
- Supports sleep mode, the power consumption down to 14.5 μ A
- Supports global license-free ISM band: EU433, CN470, EU868, US915, AS923, AU915, KR920 and IN865
- Supports I2C, GPIOs, UART, and ADC interfaces.

Specifications

Overview

The overview covers the RAK5205 WisTrio board top view and also, its block diagram with the corresponding external interfaces of the RAK5205.

Board Overview

Figure 1 shows the top view and external interfaces of the RAK5205 LPWAN tracker board.

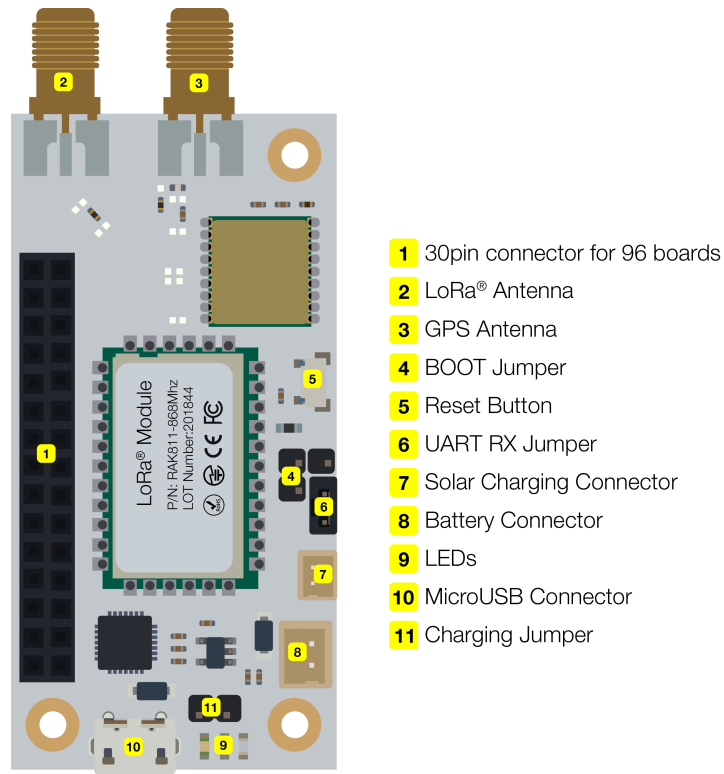

Figure 1: RAK5205 WisTrio LPWAN Tracker Interfaces

The dimension and the bottom view of the board is shown below. Sensor ICs are also labeled for your reference.

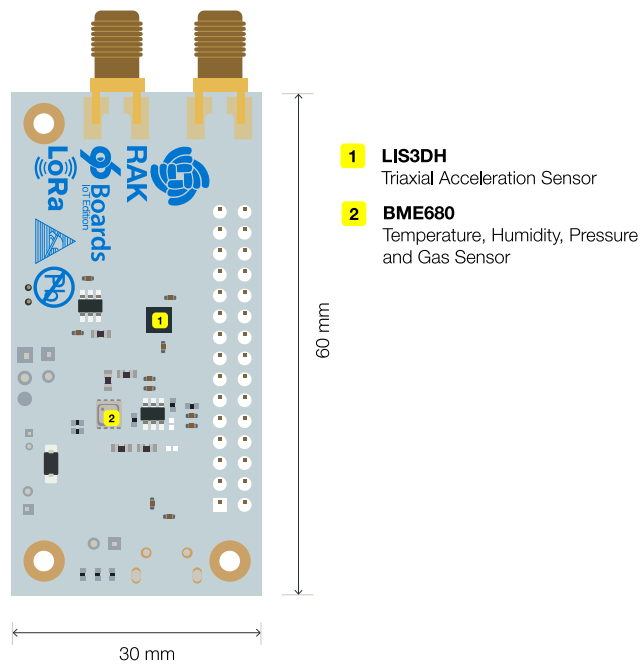

Figure 2: RAK5205 Dimension and Sensors Available

Hardware

The hardware specification is categorized into eight parts. It discusses the interfacing, pinouts, and its corresponding functions and diagrams. It also covers the parameters and standard values in terms of electrical, environmental mechanical and the antennas specifications.

Interfaces

Functional Diagram

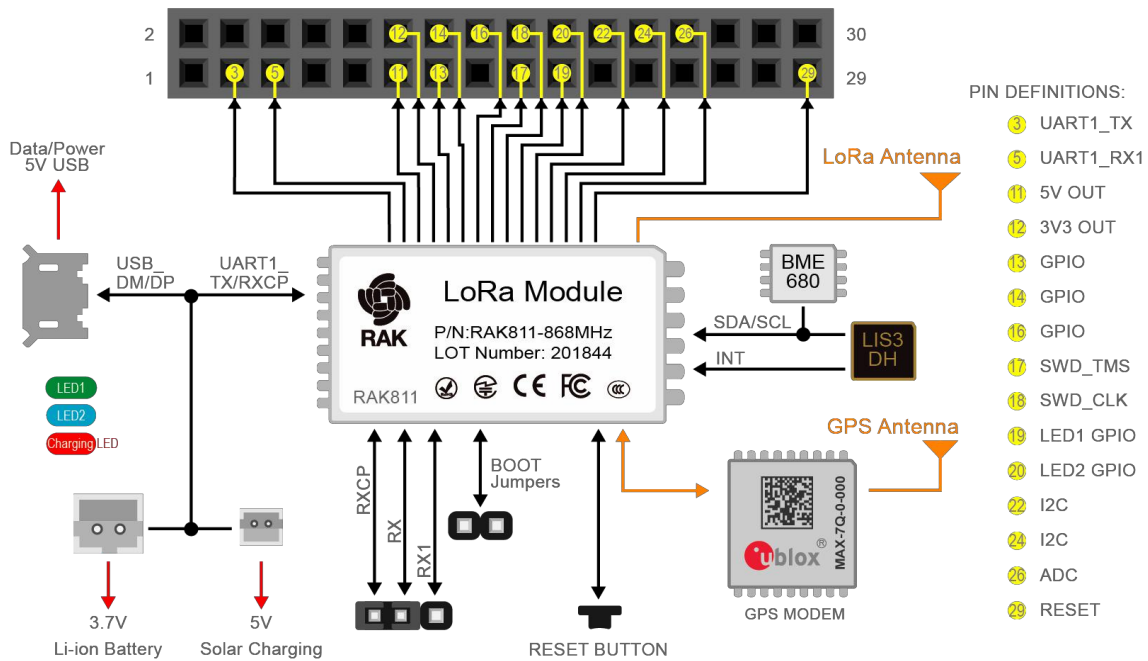

Figure 3: RAK5205 Functional Diagram

It is built around RAK811 module and compatible with 96Boards. It provides the following interfaces, headers, jumpers, button and connectors:

- Micro USB
- 30-pin 96Boards Headers (UART, RESET, GPIOs, I2C, ADC)
- 2-pin USB Boot jumper
- 3-pin UART RX jumper
- 2-pin Battery female interface
- 2-pin Solar Panel female interface
- LEDs
- Reset Button

It has two Antenna connectors:

- RP-SMA Male connector of LoRa Antenna(optional iPEX connector)
- SMA Female connector of GPS Antenna(optional iPEX connector)

Micro-B USB Interface

A Standard Micro-B USB compliant with USB 2.0 standard specification is used to provide an interface to connect to a PC for control of the board and firmware upgrade. The Micro-B USB pin definition is shown below:

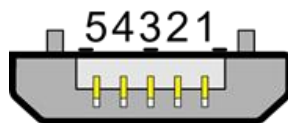





Figure 4: Micro USB Pinout

Pin	Description
1	USB_VBUS (+5 V)
2	USB_DM
3	USB_DP
4	NC
5	GND

LEDs

Three LEDs are used to indicate operating status, here are their functions:

-  **GREEN LED** : Status - Defined By User
-  **BLUE LED**: Status - Defined By User
-  **RED LED** : Charging Status - indicates the Li-ion Battery is Charging

Reset Push Button

Reset Push Button is used to reset the RAK811 module. To reset the module, push the Reset Button for one second.

Pin Definition

Here are the six connectors for RAK5205 tracker board: **P1**, **P2**, **J11**, **J12**, **J22**, and **J25**

P1

Li-ion Battery Connector: Pin1 connected to VBATT, Pin2 connected to GND

P2

Solar Cell Interface: Pin1 connected to VBUS, Pin2 connected to GND

J11

Pin1 is connected to VBUS. Pin2 is connected to VBIN. J11 should be closed when no battery is connected, and it should be open when a battery is connected.

J12

Pin1 is connected to BOOT0. Pin2 is connected to VDD. To flash a firmware, connect Pin1 and Pin2 with a jumper and reset the device. For normal operation, remove the jumper.

J22

The 30 pins follow the 96Board pin definition.



RAK5205 LoRa® Tracker PINOUT

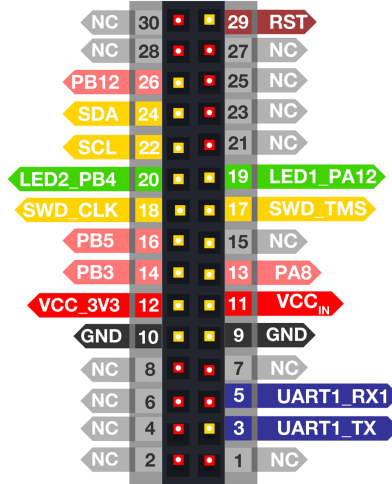
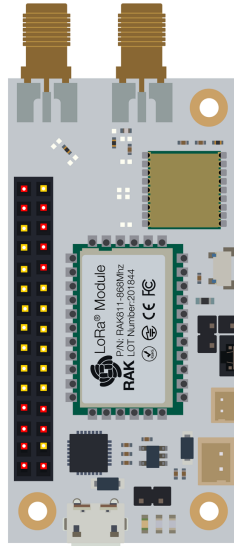

- Pins with connection
- Pins with no connection

<https://store.rakwireless.com/products/rak5205-lora-tracker>

Figure 5: RAK5205 Pinout Diagram

Pin	Pin Name	Description
1	NC	No Connection
2	NC	No Connection
3	UART1_TX	UART1_TX
4	NC	No Connection
5	UART1_RX1	UART1_RX1 (If you want to use this UART interface, need to connect RX pin and RX1 pin of J25 via jumper.).
6	NC	No Connection
7	NC	No Connection
8	NC	No Connection
9	GND	Ground
10	GND	Ground
11	VCCIN	5 V out
12	VCC_3V3	3.3 V out
13	PA8	GPIO Pin. This pin can be controlled via AT Command or RUI with GPIO number 5. (On RAK811(L) low frequency based boards like EU433, this is mapped to STM32 pin PB13).
14	PB3	GPIO Pin. This pin can be controlled via AT Command or RUI with GPIO number 15. (On RAK811(L) low frequency based boards like EU433, this is mapped to STM32 pin PA3).
15	NC	No Connection
16	PB5	GPIO Pin. This pin can be controlled via AT Command or RUI with GPIO number 16.
17	SWD_TMS	GPIO Pin / R21, R22 pull-up 10K resistor can be used as JTAG interface.
18	SWD_CLK	GPIO Pin / R21, R22 pull-up 10K resistor can be used as JTAG interface.
19	LED1_PA12	LED pin is active low. This pin can be controlled via AT Command or RUI with GPIO number 8.
20	LED2_PB4	LED pin is active low. This pin can be controlled via AT Command or RUI with GPIO number 9. (On RAK811(L) low frequency based boards like EU433, this is mapped to STM32 pin PA11).
21	NC	No Connection

Pin	Pin Name	Description
22	SCL	I ² C
23	NC	No Connection
24	SDA	I ² C
25	NC	No Connection
26	PB12	ADC Interface. This analog pin can be read via AT Command or RUI with GPIO number 2.
27	NC	No Connection
28	NC	No Connection
29	RST	Reset Pin
30	NC	No Connection

J25

To connect the Serial output to the USB connector, RX and RxCP must be connected. To connect the Serial output to the UART pins on the J22 connector, RX and RX1 must be connected.

RF Characteristics

Operating Frequencies

The board supports all LoRaWAN frequency channels as stated in the table below which is easy to configure while building the firmware from the source code.

Region	Frequency (Mhz)
Europe	EU433, EU868
China	CN470
North America	US915
Asia	AS923
Australia	AU915
Korea	KR920
Indian	IN865

Antennas

LoRa Antenna Overview

The LoRa Antenna and Interfaces are shown in Figure 6:

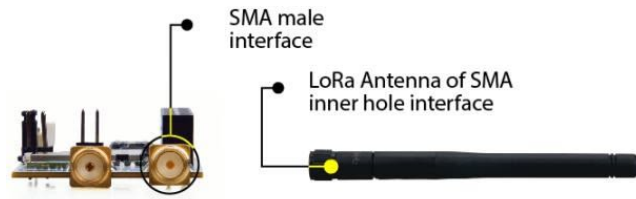

Figure 6: RP-SMA Male Connector of LoRa Antenna

Here is the iPEX LoRa Antenna Interface:

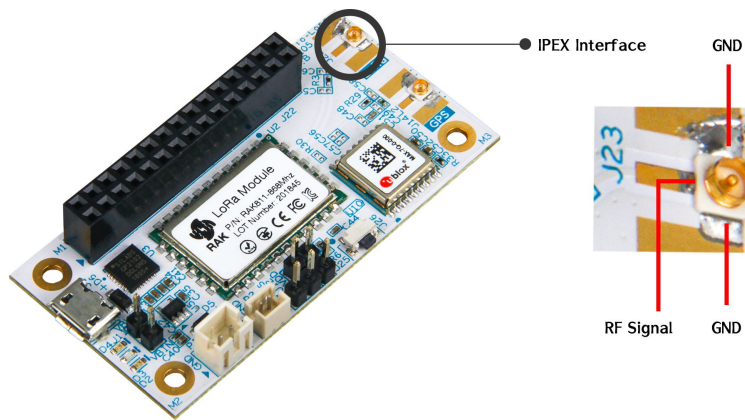

Figure 7: iPex Antenna Interface for LoRa Antenna

LoRa Antenna Dimension

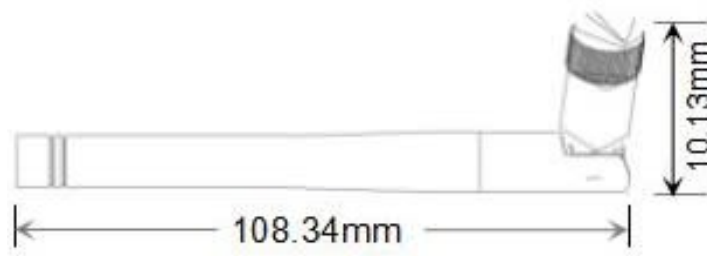

Figure 8: LoRa Antenna Dimension

LoRa Antenna Parameters

Items	Specifications
VSWR (Voltage Standard Wave Ratio)	1.5:1
Gain	2.0 dBm
Working Temperature & Humidity	T:-35 °C ~ +80 °C, H: 0% ~ 95%
Storage Temperature & Humidity	T:-40 °C ~ +85 °C, H: 0% ~ 95%

GPS Antenna

The GPS antenna and interfaces for RAK5205 tracker board is shown in Figure 9:

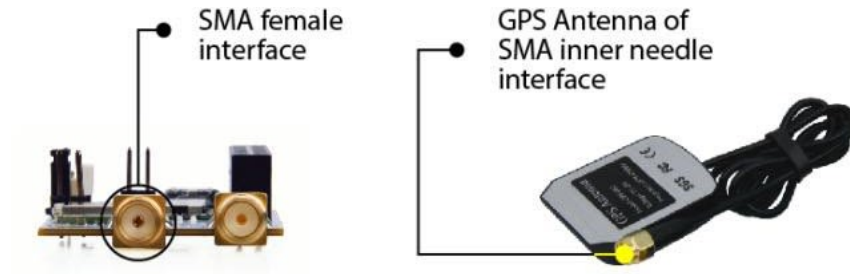

Figure 9: SMA Female Interface for GPS

Here is the iPEX GPS Antenna interface:

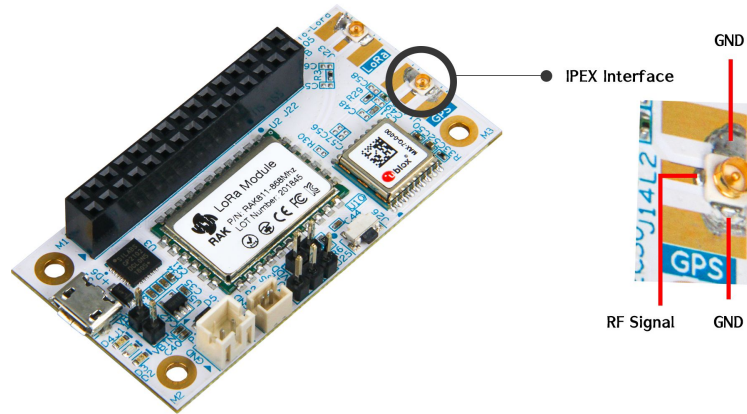

Figure 10: iPEX Interface for GPS Antenna

GPS Antenna Dimensions

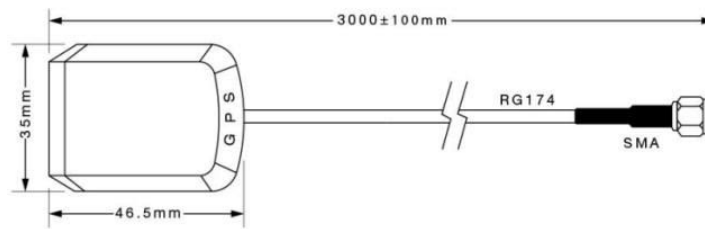

Figure 11: GPS Antenna Dimension

GPS Environmental Requirements

The antenna environmental requirements are listed in the table below:

Conditions	Temperature	Humidity
Working	-35 °C ~ +80 °C	0% ~ 95%
Storage	-40 °C ~ +85 °C	0% ~ 95%

GPS Antenna Parameter

Item	Specifications	PET
Range of Receiving Frequency	1575.42±1.1	±2.5
Center Frequency (MHz) w/ 30 mm ² GND plane	1575.42	±3.0
Bandwidth (MHz) (Return Loss ≤ -10 dB)	≥10	±0.5
VSWR (in Center Frequency)	≤2.0	±0.5
Gain (Zenith) (dBi Typ) w/ 70 mm ² GND Plane	4.5	±0.5
Axial Ratio (dB) w/ 70 mm ² GND Plane	3.0	±0.2
Polarization	Righ-Handle Circular	-
Impedance (Ω)	50	-
Frequency Temperature Coefficient (ppm/°C)	0 ±10	-

Amplifier Specifications are listed in the table below:

Item	Specifications
Frequency Range	1575.42 MHz
Gain	27 dB
VSWR	≤ 2.0 V
Noise Coefficient	≤ 2.0 dBm
DC Voltage	3 ~ 5 V
DC Current	5 ± 2 mA

Environmental test performance specifications are listed below:

Item	Normal Temp.	High Temp.	Low Temp.
Amplifier Gain	27 dB ± 2.0	27 dB ± 2.0	27 dB ± 2.0
VSWR	≤ 2.0	≤ 2.0	≤ 2.0
Noise Coefficient	≤ 2.0	≤ 2.0	≤ 2.0

NOTE

High Temperature Test: Soap in temperature (85 °C) and humidity (95%) chamber for 24-hour and return normal temperature (at least for 1-hour) without visual shape change.

Low Temperature Test: Soap in temperature (-40 °C) chamber for 24-hour and return to normal temperature (at least for 1-hour) without visual shape change.

Electrical Characteristics

Power Consumption

Working Mode

The board supports to enable the GPS low-power mode. It has a 3-axis MEMS Sensor LIS3DH, which can detect the user's motion status. When the device is stationary, it will enter the low power sleep mode, reducing the overall power consumption and increase battery life. The power consumption is shown in the following table.

Mode	Power Consumption
Sleep Mode	14.5 μ A (Minimum)
Normal Mode	174 mA (Maximum) @ 20 dBm and GPS Enabled

Power Requirements

The RAK5205 LoRa Tracker Board has an operating voltage of 3.7 V. It can be powered by micro USB with 5 V Max.

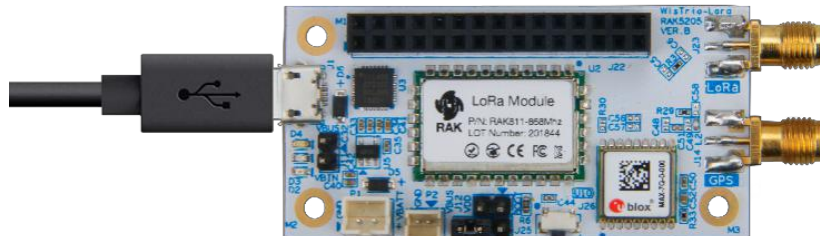

Figure 12: Powered by Micro USB

The board can also be powered by a 3.7 V Li-Ion battery. You can connect a 5 V solar panel charger to recharge the Li-Ion battery.

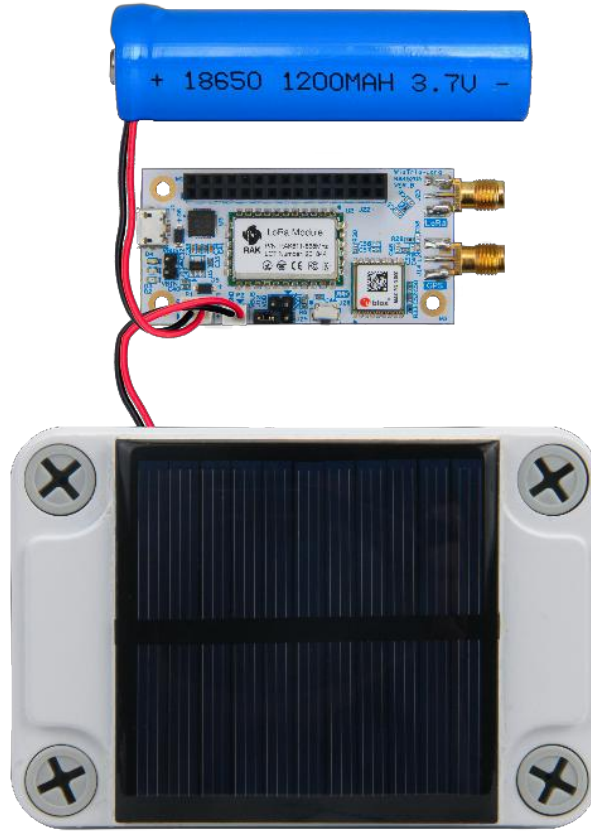

Figure 13: RAK5205 With 5V Solar Panel, Plastic Enclosure, and Li-ion Battery

Environmental Requirements

The table below lists the operation and storage temperature requirements:

Parameter	Min.	Typical	Max.
Operation Temp. Range	-35 °C	+25 °C	+60 °C
Extended Temp. Range	-40 °C	-	+80 °C
Storage Temp. Range	-40 °C	-	+80 °C

Mechanical Characteristics

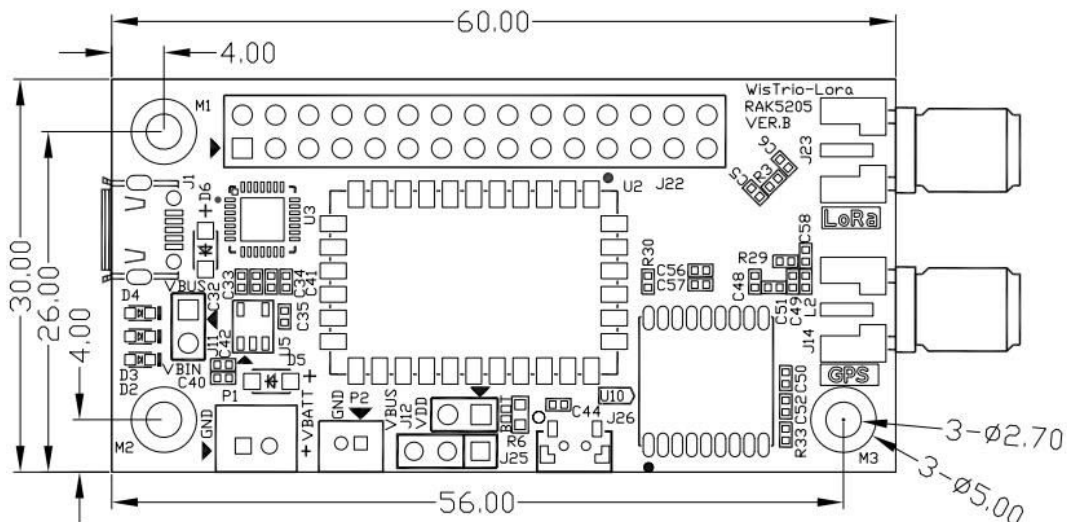

Figure 14: RAK5205 Detailed Dimensions

Schematic Diagram

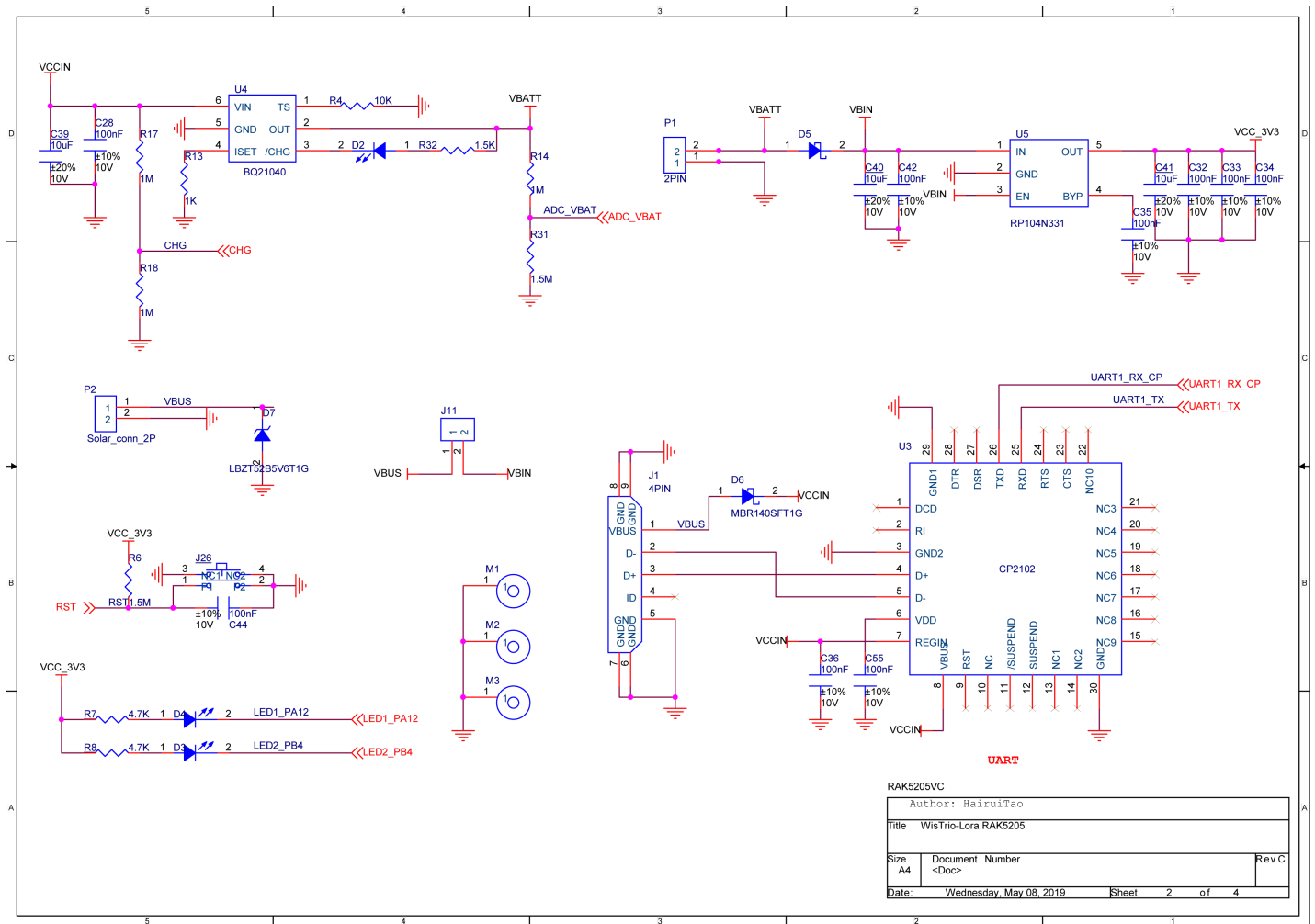

Figure 15: Schematic Diagram - 1

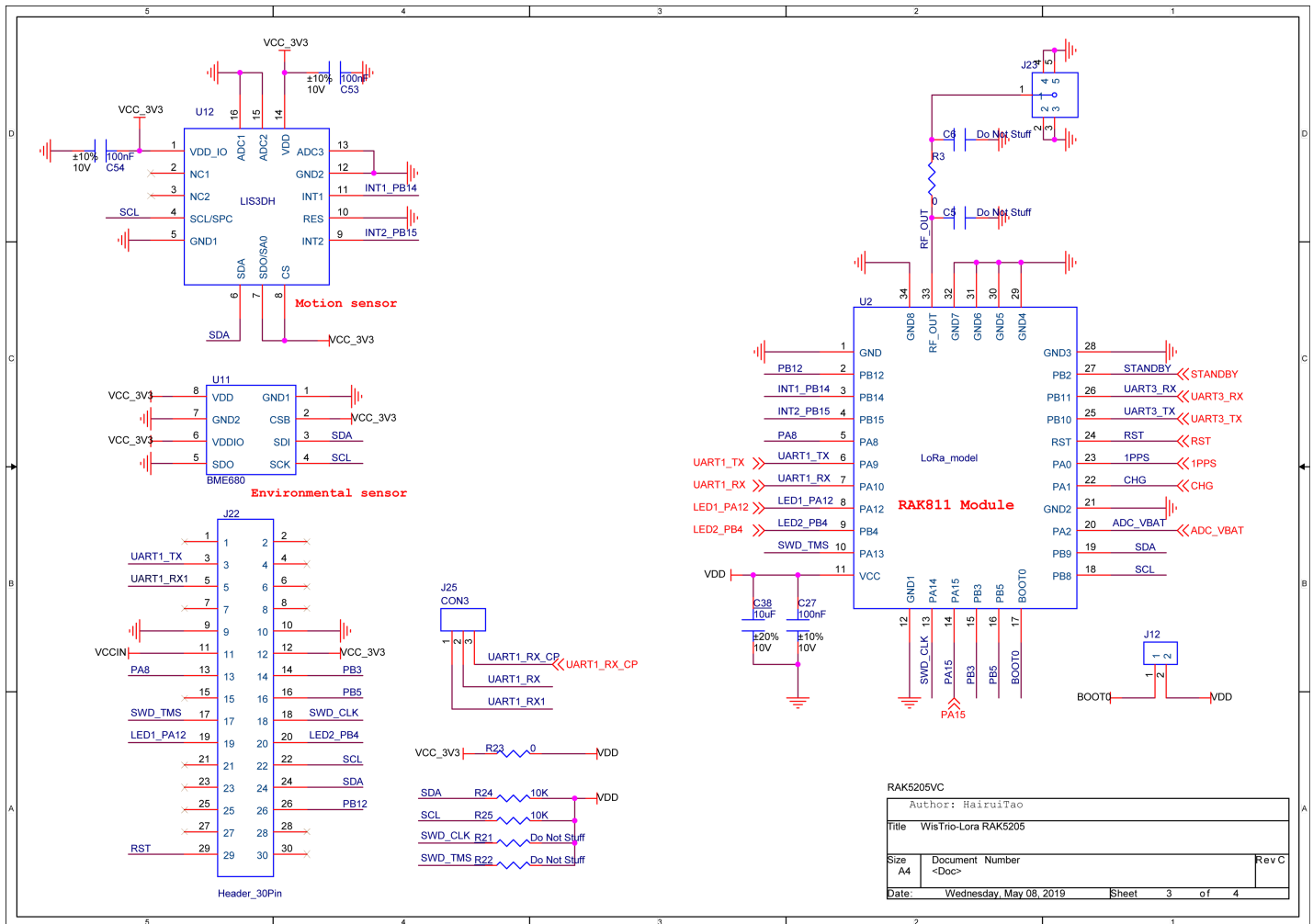

Figure 16: Schematic Diagram - 2

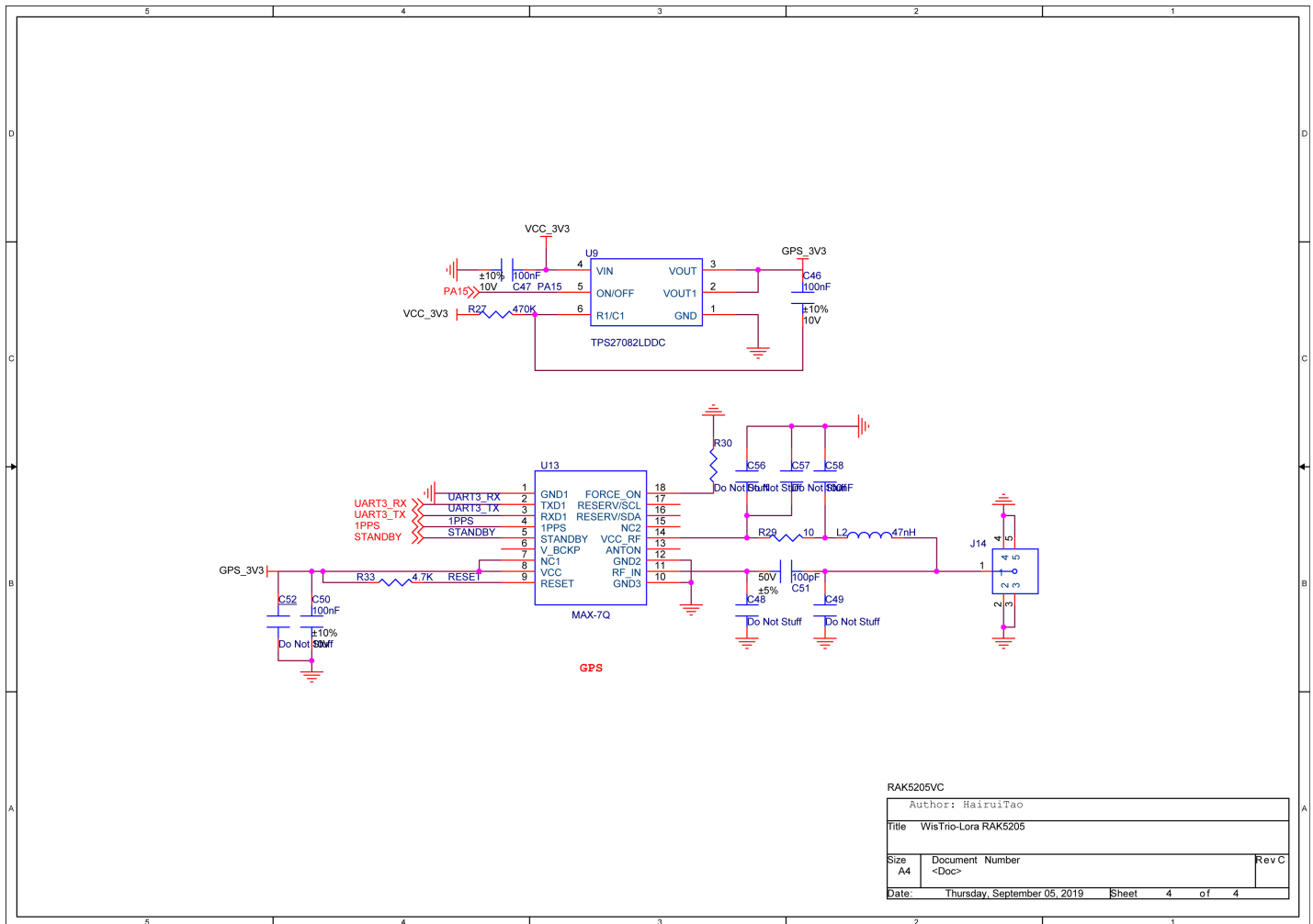



Figure 17: Schematic Diagram - 3

Software

Download the supported firmwares of RAK5205 in the table provided below.

Firmware

Model	Supported Firmwares	Version	Source
RAK5205 - H	EU868 / US915 / AU915 / KR920 / IN865	V3.0.0.14	Download 
RAK5205 - L	EU433 / CN470	V3.0.0.14	Download 

Last Updated: 3/29/2021, 4:29:51 PM