

BoT-CLE310

DATASHEET

CONFIDENTIAL INFORMATION

List of Contents

1. General	3
1.1 Overview	3
1.2 Features	4
1.3 Application	4
1.4 Pin Configuration & Outline Size	5
1.5 Device Terminal Functions	6
1.6 Software Pin Define	7
1.7 Package Dimensions & Land Pattern	8
1.8 Power Consumption.....	9
1.9 Advertising Interval Current.....	9
2. Characteristics	10
2.1 Electrical Characteristics	10
2.2 RF Characteristics.....	11
2.2.1 Transmitter	11
2.2.2 Receiver	12
2.2.3 Antenna Characteristics.....	13
3. Terminal Description.....	14
3.1 UART Interface	14
3.1.1 UART Setting.....	14
3.2 Programming and Debug Interface.....	15
3.2.1 Instruction Cycle	15
3.2.2 Multi-slave Operation.....	16
4. Layout Guide.....	17
4.1 Layout Guide	17
5. Application Schematic.....	18
5.1 Reference Application	18
5.2 Internal ANT. / 3.3V UART Application.....	18
5.3 Internal ANT. / 5V UART Application.....	18
5.4 External ANT. / 3.3V UART Application	18

1. General

1.1 Overview

This specification covers Bluetooth module which single IC Bluetooth Low Energy solution, this module provides everything required to create a Bluetooth low energy product with RF, baseband, MCU, qualified Bluetooth v4.1 stack and customer application running.

All detailed specification including pin outs and electrical specification may be changed without notice.

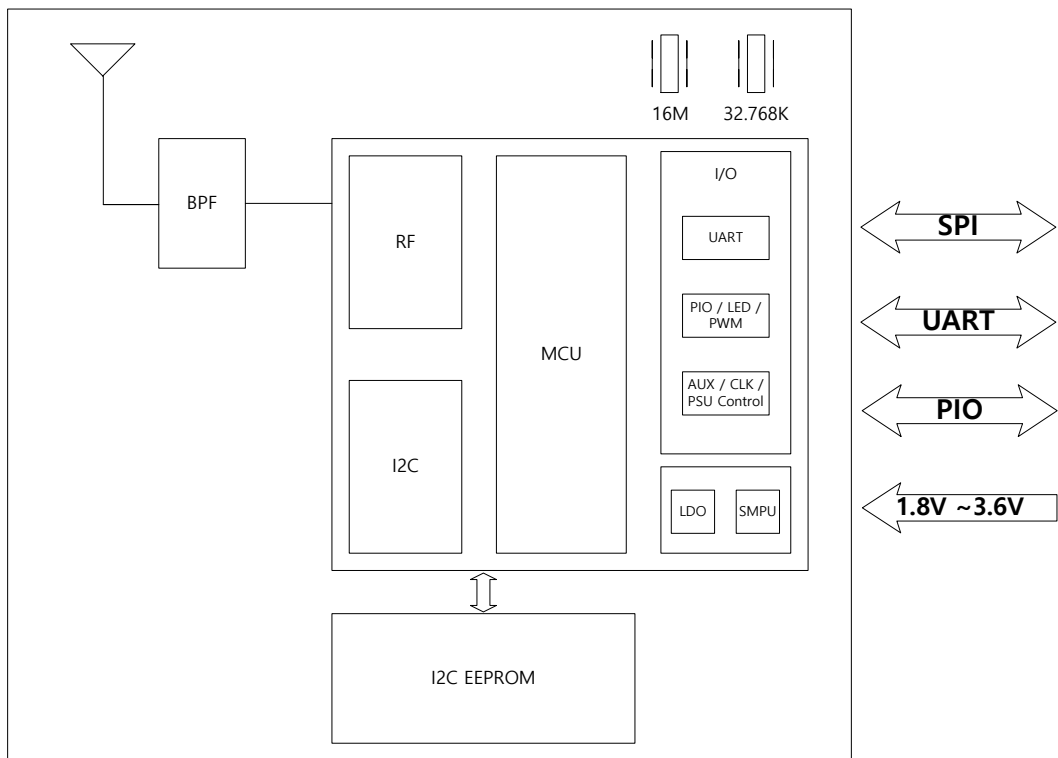

1.2 Features

- 128KB memory: 64KB RAM and 64KB ROM
- Bluetooth® v4.1 specification
- 7.5dBm Bluetooth low energy maximum transmit output power
- -92.5dBm Bluetooth low energy receive sensitivity
- Support for Bluetooth v4.1 specification host stack including ATT, GATT, SMP, L2CAP, GAP
- RSSI monitoring for proximity applications
- Programmable general purpose PIO controller
- 10-bit ADC
- 11 digital PIOs
- 2 analogue AIOs
- UART
- Debug SPI
- 4 PWM modules
- Wake-up interrupt and watchdog timer
- Competitive Size (18.7mm x 10mm x 2mm : 22Pin)
- Operating temperature range (MAX -30°C ~ 85°C)

1.3 Application

- 2.4-GHz Bluetooth low energy Systems
- Watch, Keyboard, Mouse, Remote Control
- Sport and Fitness sensors
- Health sensors
- Smart Home
- Mobile Phone Accessories

1.4 Pin Configuration & Outline Size

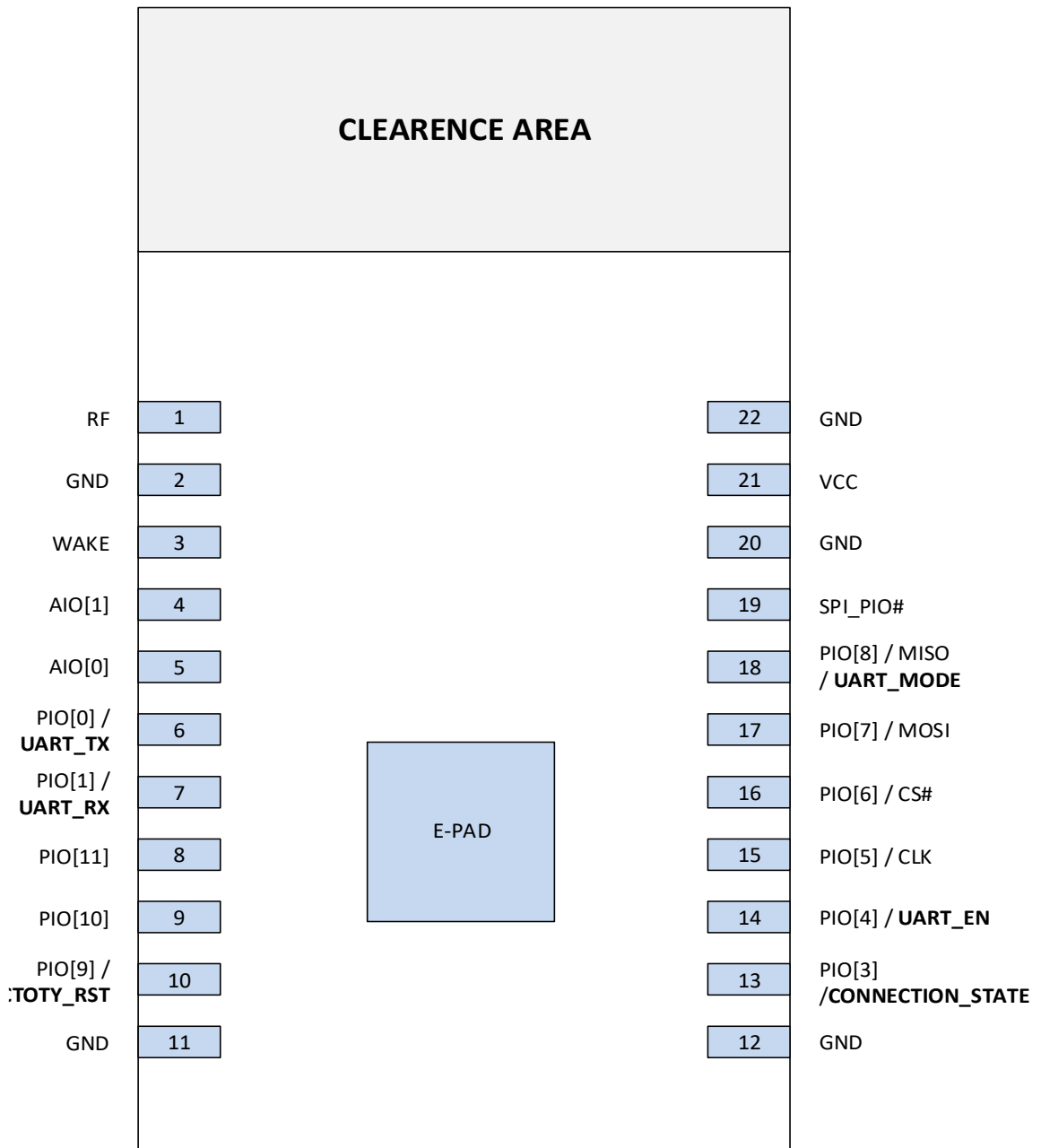

PIN MAP(Top view)

Pin Configuration (TOP VIEW)

1.5 Device Terminal Functions

Function		Pin Name	Pin No.	Pin Type	Description	Note	
RF	RF	RF	1		RF IN/OUT		
AIO	AIO[0]	AIO[0]	5	Bidirectional analogue	Analogue programmable I/O line		
	AIO[1]	AIO[1]	4	Bidirectional analogue	Analogue programmable I/O line		
PIO	PIO[0]	UART_TX	PIO[0]	6	Bidirectional	Programmable I/O line or UART TX	
	PIO[1]	UART_RX	PIO[1]	7	Bidirectional	Programmable I/O line or UART RX	
	PIO[3]		PIO[3]	13	Bidirectional	Programmable I/O line	
	PIO[4]		PIO[4]	14	Bidirectional	Programmable I/O line	
	PIO[5]	SPI_CLK	PIO[5]	15	Bidirectional	Programmable I/O line or debug SPI_CLK selected by SPI_PIO#	
	PIO[6]	SPI_CS#	PIO[6]	16	Bidirectional	Programmable I/O line or debug SPI_CS# selected by SPI_PIO#	
	PIO[7]	SPI_MOSI	PIO[7]	17	Bidirectional	Programmable I/O line or debug SPI_MOSI selected by SPI_PIO#	
	PIO[8]	SPI_MISO	PIO[8]	18	Bidirectional	Programmable I/O line or debug SPI_MISO selected by SPI_PIO#	
	PIO[9]		PIO[9]	10	Bidirectional	Programmable I/O line	
	PIO[10]		PIO[10]	9	Bidirectional	Programmable I/O line	
	PIO[11]		PIO[11]	8	Bidirectional	Programmable I/O line	
Control	SPI_PIO#	SPI_PIO#	19	Input with strong internal Pull-down	Selects SPI debug on PIO[8:5]	*High = SPI *High = PIO	
	WAKE	WAKE	3	Input has no internal pull-up or Pull-down	Input to wake CSR1010QFN form hibernate or dormant.		
Power	VCC	VCC	19	Power	Battery input and regulator enable (active high)		
	GND	GND	2,11,12,20,22, EPAD	GND	Ground	25pin BOTTOM PAD	

1.6 Software Pin Define

Function		Pin Name	Pin No.	Description	
AIO	AIO[0]	AIO[0]	5	Analogue Input (0~1.28v)	
	AIO[1]	AIO[1]	4	Analogue Input (0~1.28v)	
PIO	PIO[0]	UART_TX	PIO[0]	6	Programmable I/O line or UART TX
	PIO[1]	UART_RX	PIO[1]	7	Programmable I/O line or UART RX
	PIO[3]		PIO[3]	13	Connection Detect LED Output (Low=Disconnect, High=Connect)
	PIO[4]		PIO[4]	14	UART Select (Low=off, High=On)
	PIO[5]	SPI_CLK	PIO[5]	15	PWM0, PWM Output (0~255)
	PIO[6]	SPI_CS#	PIO[6]	16	PWM1, PWM Output (0~255)
	PIO[7]	SPI_MOSI	PIO[7]	17	PWM2, PWM Output (0~255)
	PIO[8]	SPI_MISO	PIO[8]	18	AT COMMAND(high)/DATA MODE(low) SELECT
	PIO[9]		PIO[9]	10	Factory Reset (Active High, 4초 이상)
	PIO[10]		PIO[10]	9	Digital Input or Output port
	PIO[11]	PIO[11]	8	Digital Input or Output port	
Control	SPI_PIO#	SPI_PIO#	19	Selects SPI debug on PIO[8:5] SPI(high), PIO(low)	

1.7 Package Dimensions & Land Pattern

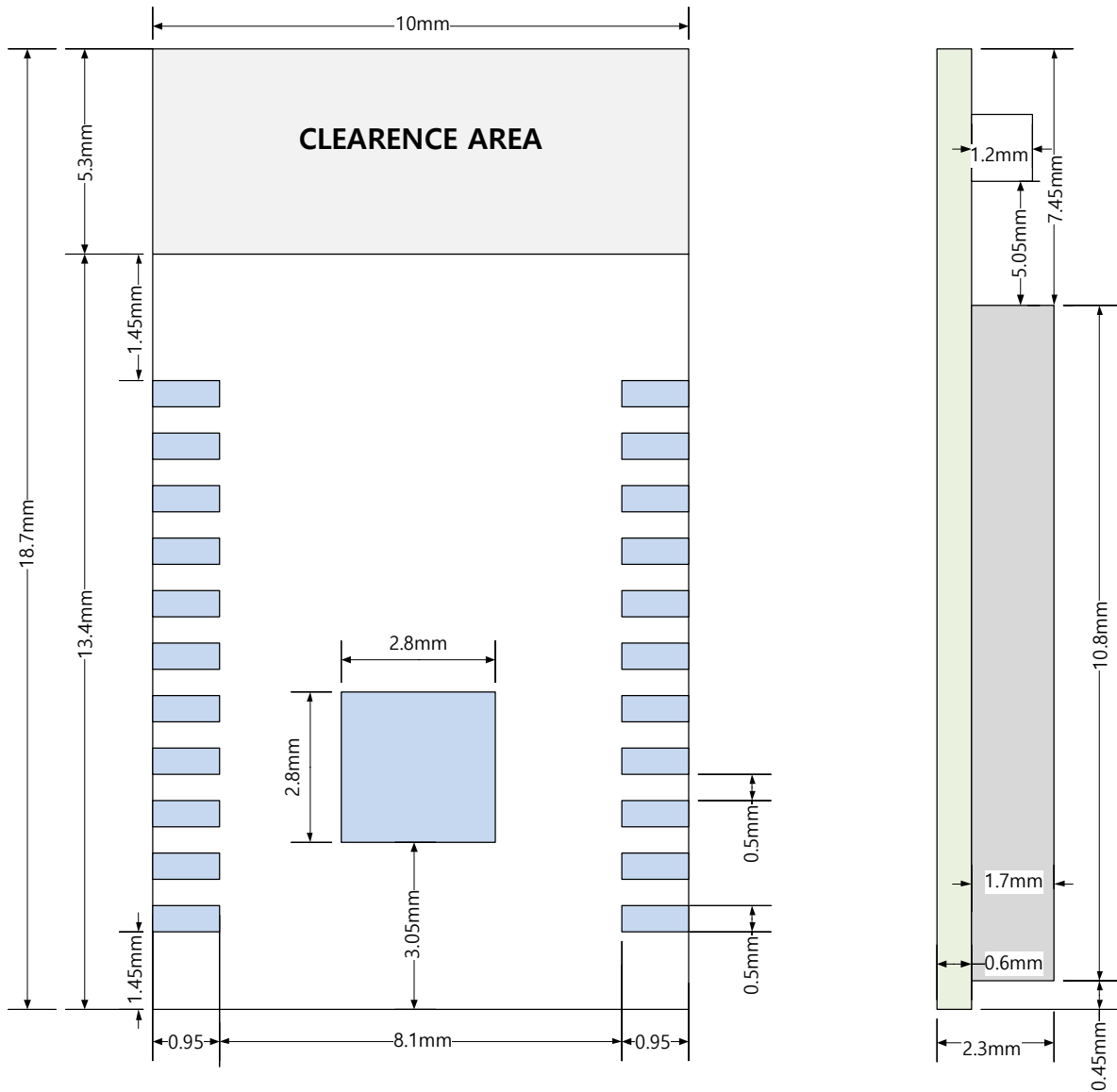

Package Dimensions (TOP VIEW)

1.8 Power Consumption

UART ON	
Discovering	1.533mA
Connected	1.694mA

* Advertising Interval : 1280ms

* Connection Interval : 500ms

UART ON	
Scanning	20mA
Connected	1.64mA

* Scan Window Size : 400ms

Scan Interval : 400ms

* Connection Interval : 500ms

UART OFF (Deep Sleep)
31μA

1.9 Advertising Interval Current

UART ON

단위(mA)

dBm	Adv Interval(ms)				
	160	320	640	1280	2560
-6 dBm	1.679	1.602	1.570	1.552	1.541
-2 dBm	1.694	1.622	1.577	1.553	1.547
2 dBm	1.714	1.633	1.583	1.554	1.560
6 dBm	1.775	1.642	1.587	1.557	1.563

UART OFF

단위(mA)

dBm	Adv Interval(ms)				
	160	320	640	1280	2560
-6 dBm	0.180	0.094	0.050	0.028	0.015
-2 dBm	0.192	0.099	0.051	0.031	0.016
2 dBm	0.210	0.107	0.056	0.033	0.017
6 dBm	0.240	0.123	0.064	0.037	0.021

2. Characteristics

2.1 Electrical Characteristics

■ Absolute Maximum Ratings

Rating	Min	Max	Unit
Storage Temperature range	-40	85	°C
Supply (VCC) voltage	1.8	3.6	V
Other terminal voltages	VSS-0.4	VDD+0.4	V

■ Recommended Operating Conditions

Operating Condition	Min	TYP	Max	Unit
Operating temperature range	-30	-	85	°C
Supply (VCC) voltage	1.8	-	3.6	V

■ Digital Input / Output Terminal Characteristics

Input Voltage Levels	Min	TYP	Max	Unit
VIL input logic level low	-0.4	-	0.3 x VCC	V
VIH input logic level high	0.7 x VCC	-	VCC + 0.4	V
Tr/Tf	-	-	25	ns

Output Voltage Levels	Min	TYP	Max	Unit
VOL output logic level low, IOL = 4.0mA	-	-	0.4	V
VOH output logic level high, IOH = -4.0mA	0.75 x VCC	-	-	V
Tr/Tf	-	-	5	ns

■ PIO & AIO Recommended Operating Conditions

Output Voltage Levels	Min	TYP	Max	Unit
Input voltage	-	-	1.35	V
Output voltage	-	-	1.35	V

2.2 RF Characteristics

2.2.1 Transmitter

RF Characteristics		MIN	TYP	Max	Bluetooth Specification	Unit	Note
Maximum RF transmit power		3.5 @ -30 °C 3.5 @ 20 °C 2 @ 85 °C	7.5 @ -30 °C 7.5 @ 20 °C 6 @ 85 °C	-	-20 to 10	dBm	(1) (2)
ACP	F = F ₀ ± 2MHz	-	-28 @ -30 °C -28 @ 20 °C -29 @ 85 °C	-20	≤ -20	dBm	(3) (4)
	F = F ₀ ± 3MHz	-	-32 @ -30 °C -32 @ 20 °C -35 @ 85 °C	-22 @ -30 °C -22 @ 20 °C -23 @ 85 °C	≤ -30	dBm	(3) (4)
	F = F ₀ ± > 3MHz	-	< -55	-24 @ -30 °C -27 @ 20 °C -40 @ 85 °C	≤ -30	dBm	(3) (4)
Δf _{1avg} maximum modulation		225	258	275	225 < f _{1avg} < 275	kHz	-
Δf _{2max} minimum modulation		185	197	-	≥ 185	kHz	-
Δf _{2avg} / Δf _{1avg}		0.8	0.86	-	≥ 0.80	-	-
ICFT		-35	10 @ -30 °C 5 @ 20 °C 10 @ 85 °C	35	±150	kHz	(5)
Carrier drift rate		-	11 @ -30 °C 8 @ 20 °C	20	≤ 20	kHz/50μs	-
Carrier drift		-	6 @ -30 °C 7 @ 20 °C 8 @ 85 °C	50	≤ 50	kHz	-
2 nd harmonic content		-	-34	-	-	dBm	(6)
3 rd harmonic content		-	-32	-	-	dBm	(6)

Note:

- (1) The firmware maintains the transmit power within Bluetooth v4.0 specification limits
- (2) Illustrative: Can be varied under firmware control on an application-dependent basis down to approximately -20dbm
- (3) Measured at F₀ = 2440MHz
- (4) CSR1010A04 QFN guaranteed to meet ACP performance in Bluetooth v4.0 specification
- (5) Ignores any frequency error in the reference
- (6) Addition of a filter attenuates the harmonics

2.2.2 Receiver

RF Characteristics	Frequency (GHz)	MIN	TYP	Max	Bluetooth Specification	Unit	Note
Sensitivity at 30.8% PER for all basic rate packet types	2.402	@ -30 °C @ 20 °C @ 85 °C	-92.5 @ -30 °C -92 @ 20 °C -89 @ 85 °C	-88.5 @ -30 °C -88 @ 20 °C -85 @ 85 °C	≤-70	dBm	-
	2.44	-	-93 @ -30 °C -92.5 @ 20 °C -89.5 @ 85 °C	-89 @ -30 °C -88.5 @ 20 °C -85.5 @ 85 °C			-
	2.48	-	-93 @ -30 °C -92.5 @ 20 °C -89.5 @ 85 °C	-89 @ -30 °C -88.5 @ 20 °C -85.5 @ 85 °C			-
Reported PER during PER report integrity test	2.426	50	50	65.4	50 < PER < 65.4	%	(1)
Maximum received signal at 30.8% PER		-10	> -10	-	≥-10	dBm	-
Continuous power required to block Bluetooth reception (for input power of -67dBm with 30.8% PER) measured at the single-ended RF port of CSR1010A04 QFN	0.030 - 2.000	-35	> 3	-	-30	dBm	(2)
	2.000 - 2.400	-35	-3	-	-35		(2)
	2.500 - 3.000	-35	-3	-	-35		(2)
	3.000 - 12.75	-30	>3	-	-30		(2)
C/I co-channel		-	6	21	≤21	dBm	(3) (4) (5)
Adjacent channel selectivity C/I	$F = F_0 + 1\text{MHz}$	-	2	15	≤15	dB	(3) (4) (5)
	$F = F_0 - 1\text{MHz}$	-	1	15	≤15		(3) (4) (5)
	$F = F_0 + 2\text{MHz}$	-	-28	17	≤-17		(3) (4) (5)
	$F = F_0 - 2\text{MHz}$	-	-21	15	≤-15		(3) (4) (5)
	$F = F_0 + 3\text{MHz}$	-	-31	27	≤-27		(3) (4) (5)
	$F = F_0 - 5\text{MHz}$	-	-30	27	≤-27		(3) (4) (5)
	$F = F_{\text{image}}$	-	-24	-9	≤-9		(3) (4) (5)
Maximum level of intermodulation interferers		-50	-33	-	≥-50	dBm	(6)
Spurious output level		-	154	-	-	dBm / Hz	(7)

Note:

(1) Measured in accordance with the RCV-LE/CA/07/C test. Random number of packets transmitted by tester of which 50% have corrupted CRCs. Wanted signal level is -30dBm.

(2) CSR1010A04 QFN is guaranteed to meet the blocking performance as specified by the Bluetooth v4.0 specification.

(3) CSR1010A04 QFN is guaranteed to meet the C/I performance as specified by the Bluetooth v4.0 specification.

(4) Measured at $F_0 = 2440\text{MHz}$.

(5) $F_{\text{image}} = F_0 - 3\text{MHz}$. However, depending on crystal frequency and channel number, the image may switch to the opposite side of the carrier. When this occurs, $F_{\text{image}} = F_0 + 3\text{MHz}$ and the offsets in the table equations associated with C/I are also reversed.

(6) Measured at $f_1 - f_2 = \pm 3, 4$ and 5MHz . Measurement is performed in accordance with Bluetooth RF test RCV-LE/CA/05/C, i.e. wanted signal at -64dBm.

(7) Integrated in 100kHz bandwidth and normalised to 1Hz. Actual figure is typically -154dBm/Hz except for peaks of -82dBm at 1600MHz and -82dBm in-band at 2.4GHz.

2.2.3 Antenna Characteristics

The antenna is monopole type of chip antenna. The antenna impedance matching is optimized for 1 mm ~ 2 mm mother board PCB thickness. The radiation pattern is impacted by the layout of the mother board. Typically the highest gain is towards GND plane and weakest gain away from the GND plane.

■ S-Parameter

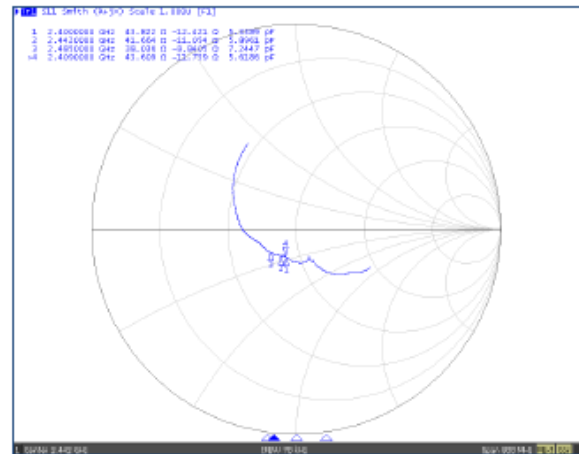
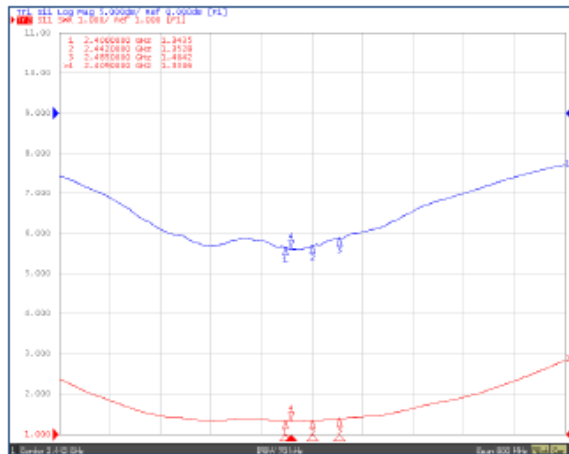

■ Radiation Gain

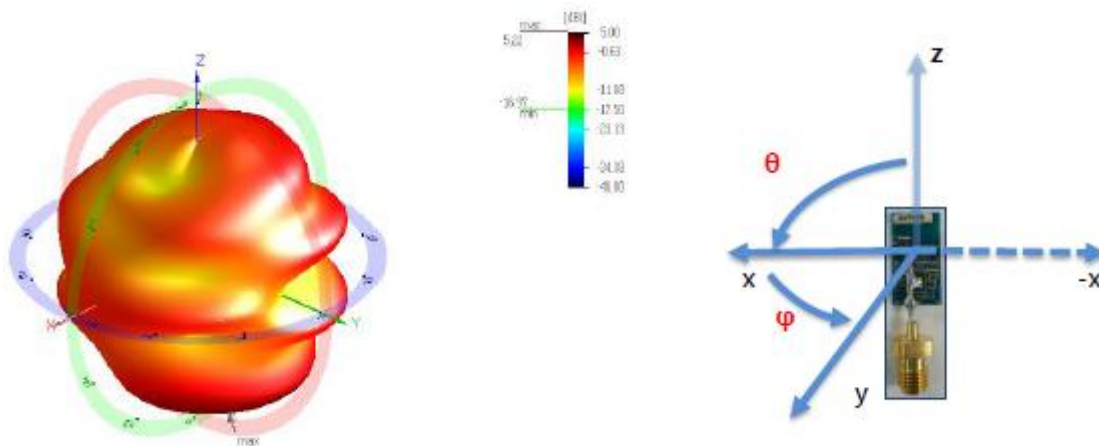

Freq (GHz)	Efficiency (%)	Avg. Gain (dBi)	Peak Gain (dBi)
2400 MHz	62.22	-2.06	4.18
2440 MHz	63.67	-1.96	4.11
2485 MHz	68.14	-1.67	3.99

3. Terminal Description

3.1 UART Interface

BoT-CLE310 UART interface provides a simple mechanism for communicating with other serial devices using the RS232 protocol.

The 2 signals implement the UART function, UART_TX and UART_RX. When BoT-CLE310 is connected to another digital device, UART_RX and UART_TX transfer data between the 2 devices. UART configuration parameters, e.g. baud rate and data format, are set using BoT-CLE310 firmware.

When selected in firmware PIO[0] is assigned to a UART_TX output and PIO[1] is assigned to a UART_RX input. The UART CTS and RTS signals can be assigned to any PIO pin by the BoT-CLE310 firmware

3.1.1 UART Setting

To communicate with the UART at its maximum data rate using a standard PC, the PC requires an accelerated serial port adapter card.

However, The maximum baud rate is 9600 baud during deep sleep.

Parameter		Possible values
Baud rate	Minimum	1200 baud($\leq 2\%$ Error)
	Maximum	9600 baud($\leq 1\%$ Error)
Flow control		RTS/CTS
Parity		None, Odd or Even
Number of stop bits		1 or 2
Bits per byte		8

3.2 Programming and Debug Interface

Important Note:

The BoT-CLE310 debug SPI interface is available in SPI slave mode to enable an external MCU to program and control the BoT-CLE310, generally via libraries or tools supplied by CSR. The protocol of this interface is proprietary. The 4 SPI debug lines directly support this function.

The SPI programs, configures and debugs the BoT-CLE310. It is required in production. Ensure the 4 SPI signals are brought out to either test points or a header.

Take SPI_PIO#_SEL high to enable the SPI debug feature on PIO[8:5].

BoT-CLE310 uses a 16-bit data and 16-bit address programming and debug interface. Transactions occur when the internal processor is running or is stopped. Data is written or read one word at a time, or the auto-increment feature is available for block access.

3.2.1 Instruction Cycle

The BoT-CLE310 is the slave and receives commands on DEBUG_MOSI and outputs data on DEBUG_MISO.

1	Reset the SPI interface	Hold DEBUG_CS# high for 2 DEBUG_CLK cycles
2	Write the command word	Take DEBUG_CS# low and clock in the 8-bit command
3	Write the address	Clock in the 16-bit address word
4	Write or read data words	Clock in or out 16-bit data word(s)
5	Termination	Take DEBUG_CS# high

With the exception of reset, DEBUG_CS# must be held low during the transaction. Data on DEBUG_MOSI is clocked into the CSR1010 QFN on the rising edge of the clock line DEBUG_CLK. When reading, BoT-CLE310 replies to the master on DEBUG_MISO with the data changing on the falling edge of the DEBUG_CLK. The master provides the clock on DEBUG_CLK. The transaction is terminated by taking DEBUG_CS# high.

The auto increment operation on the BoT-CLE310 cuts down on the overhead of sending a command word and the address of a register for each read or write, especially when large amounts of data are to be transferred. The auto increment offers increased data transfer efficiency on the BoT-CLE310 QFN. To invoke auto increment, DEBUG_CS# is kept low, which auto increments the address, while providing an extra 16 clock cycles for each extra word written or read.

3.2.2 Multi-slave Operation

Do not connect the BoT-CLE310 in a multi-slave arrangement by simple parallel connection of slave MISO lines. When BoT-CLE310 is deselected ($\text{DEBUG_CS\#} = 1$), the DEBUG_MISO line does not float. Instead, BoT-CLE310 outputs "0" if the processor is running or "1" if it is stopped.

4. Layout Guide

4.1 Layout Guide

For optimal performance of the antenna place the module at the outside of the PCB

Do not place any metal (traces, components, battery etc.) within the clearance area of the antenna. Connect all the GND pins directly to a solid GND plane. Place the GND vias as close to the GND pins as possible. Use good layout practices to avoid any excessive noise coupling to signal lines or supply voltage lines. Avoid placing plastic or any other dielectric material closer than 5 mm from the antenna. Any dielectric closer than 5 mm from the antenna will detune the antenna to lower frequencies.

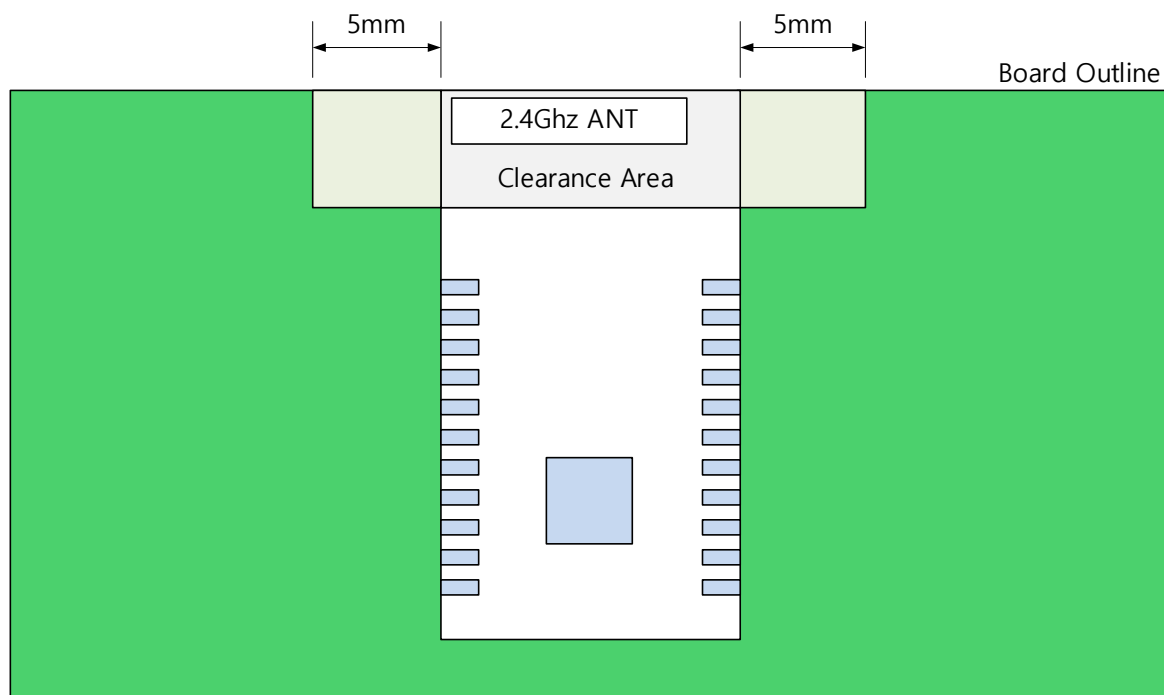

5. Application Schematic

5.1 Reference Application

5.2 Internal ANT. / 3.3V UART Application

5.3 Internal ANT. / 5V UART Application

5.4 External ANT. / 3.3V UART Application

- All reference applications are attached next page.

BoT-CLE310 REF. APPLICATION

AIO



※ AIO

구분	RANGE	비고
INPUT VOLTAGE	0 - 1.28 V	1 STEP 당 약 1mV 증감
STEP	0 - 1280	0x0500

GPIO



※ 범용 입출력 포트 (GPIO10/GPIO11)

GPIO 10 / GPIO 11 포트를 용도에 맞게 입력/출력으로 설정하여 사용할 수 있다. AT+DIR, AT+PIO 등의 Command 명령어와 조합하여 사용이 가능하다. 기본값은 입력으로 되어 있다.

FACTORY RESET



※ FACTORY_RST/PIO[9]

DEFAULT SETTING은 INPUT 설정
4초 이상 HIGH 유지시 +OK 응답 후 공장초기화 상태로 복귀시킨다.

CONN_STATUS LED OPTION

■ CONNECTION STATE

OUTPUT	DESCRIPTION
HIGH	DEVICE CONNECTION
LOW	DEVICE DISCONNECTION

■ EXAMPLE 1

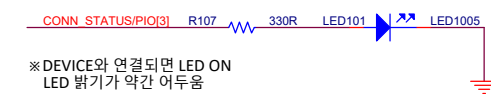

※ DEVICE와 연결되면 LED ON
LED 밝기가 약간 어두움

■ EXAMPLE 2

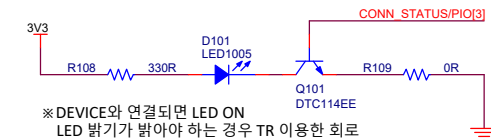

※ DEVICE와 연결되면 LED ON
LED 밝기가 밝아야 하는 경우 TR 이용한 회로

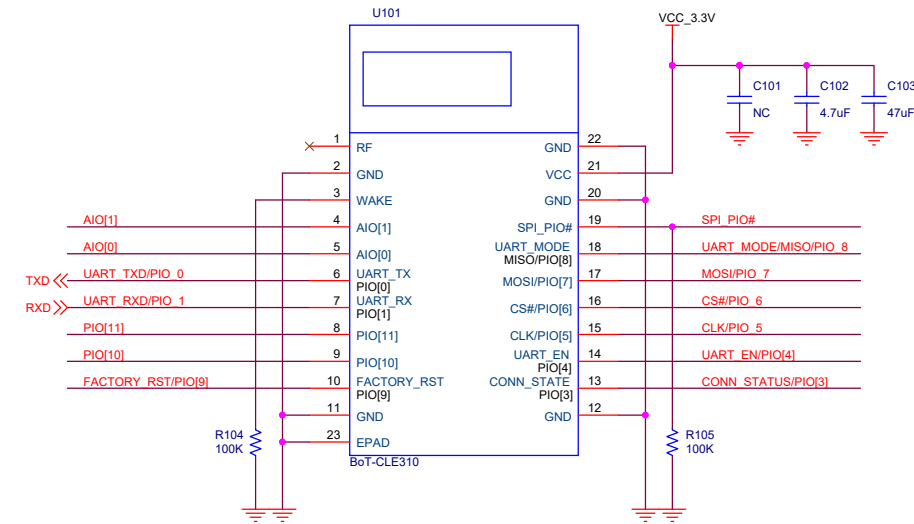

SPI PORT



■ SPI_PIO#

INPUT	DESCRIPTION
HIGH	PIO[8:5] SPI DEBUG SPI MODE ON
LOW	PIO[8:5] PROGRAMMABLE I/O MODE

※ F/W UPDATE 및 무선 인증 시 사용됩니다.
TP 또는 HEADER 설계 적용

UART PORT

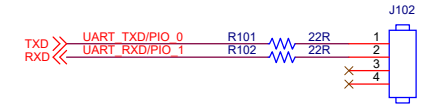

UART EN

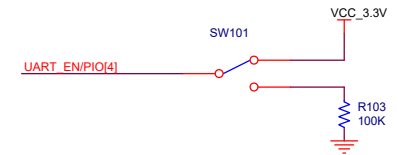

■ UART EN

INPUT	DESCRIPTION
HIGH	UART ENABLE
LOW	UART DISABLE

※ UART 통신을 사용하려면 무조건 UART EN PIN에 HIGH 입력해야 한다.

UART MODE

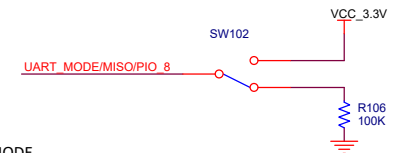

■ UART MODE

INPUT	DESCRIPTION
HIGH	AT COMMAND MODE
LOW	BYPASS MODE (DATA MODE)

※ DEVICE와 연결되기 전에는 AT COMMAND MODE로 동작
※ DEVICE와 연결 후 UART MODE PIN HIGH,LOW로 UART MODE 동작 결정

CHIPSEN Co.,Ltd.
www.chipsen.com
해 장 : 1599-6885
사 후 실 : 1599-6005

chipSEN

Title: **BoT-CLE310 REF APPLICAITON**

Size A3	Document Number BoT-CLE310 REF APPLICAITON	Rev 1.0
---------	--	---------

Date: Wednesday, December 30, 2020 Sheet 1 of 4

BoT-CLE310 REF. APPLICATION

Example Schematic

- INTERNAL ANTENNA
- UART always On
- UART 3.3V level input
- Bypass in Bluetooth connected state

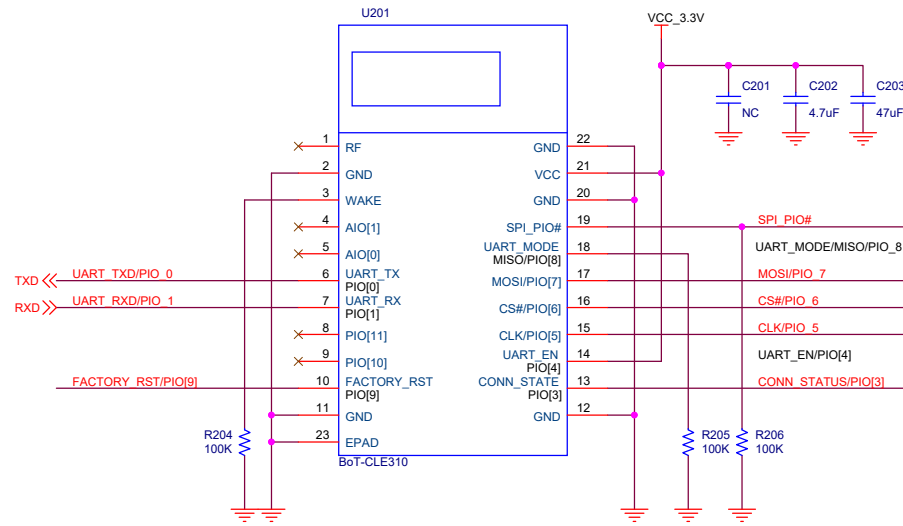

SPI PORT



■ SPI_PIO#

INPUT	DESCRIPTION
HIGH	PIO[8:5] SPI DEBUG SPI MODE ON
LOW	PIO[8:5] PROGRAMMABLE I/O MODE

※ F/W UPDATE 및 무선 인증 시 사용됩니다.
TP 또는 HEADER 설계 적용

UART PORT



UART EN

■ Example

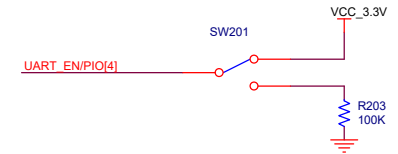

■ UART EN

INPUT	DESCRIPTION
HIGH	UART ENABLE
LOW	UART DISABLE

※ UART 통신을 사용하려면 무조건 UART EN PIN에 HIGH 입력해야 한다.

UART MODE

■ Example

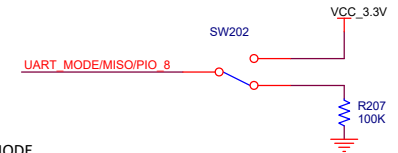

■ UART MODE

INPUT	DESCRIPTION
HIGH	AT COMMAND MODE
LOW	BYPASS MODE (DATA MODE)

※ DEVICE와 연결되기 전에는 AT COMMAND MODE로 동작

※ DEVICE와 연결 후 UART MODE PIN HIGH, LOW로 UART MODE 동작 결정

FACTORY RESET



※ FACTORY_RST/PIO[9]

DEFAULT SETTING은 INPUT 설정
4초 이상 HIGH 유지시 +OK 응답 후 공장초기화 상태로 복귀시킨다.

CHIPSEN Co.,Ltd.
www.chipsen.com
해 장 : 1599-6885
사무실 : 1599-6005

Title: **BoT-CLE310 REF APPLICAITON**

Size: A3	Document Number: INTERNAL ANT. / UART ON / UART 3.3V	Rev: 1.0
----------	--	----------

Date: Wednesday, December 30, 2020 Sheet 2 of 4

BoT-CLE310 REF. APPLICATION

Example Schematic

- INTERNAL ANTENNA
- UART always On
- UART 5 V level input
- Bypass in Bluetooth connected state

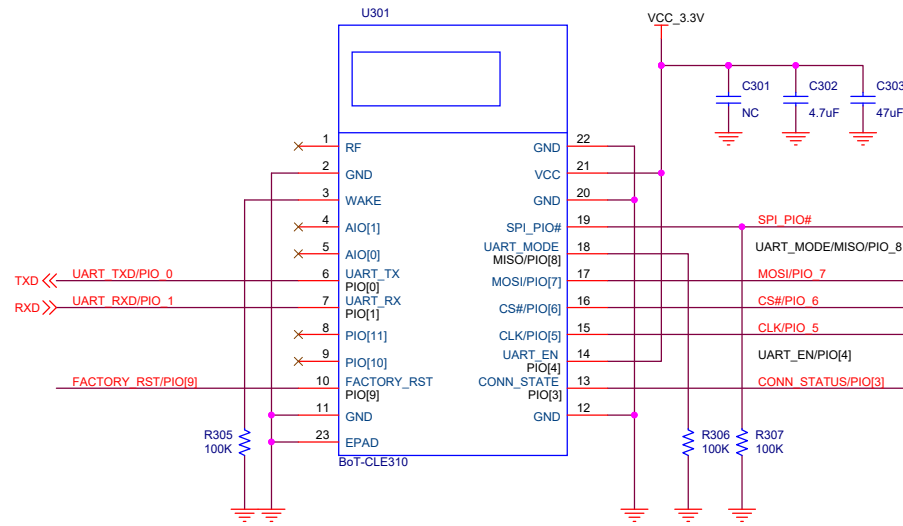

SPI PORT

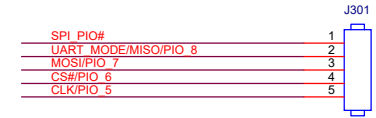

■ SPI_PIO#

INPUT	DESCRIPTION
HIGH	PIO[8:5] SPI DEBUG SPI MODE ON
LOW	PIO[8:5] PROGRAMMABLE I/O MODE

※ F/W UPDATE 및 무선 인증 시 사용됩니다.
TP 또는 HEADER 설계 적용

UART PORT

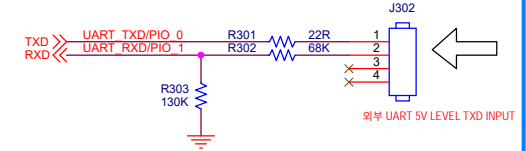

UART EN

■ Example

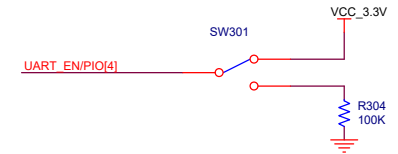

■ UART EN

INPUT	DESCRIPTION
HIGH	UART ENABLE
LOW	UART DISABLE

※ UART 통신을 사용하려면 무조건 UART EN PIN에 HIGH 입력해야 한다.

UART MODE

■ Example

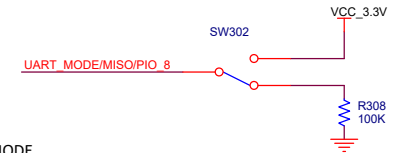

■ UART MODE

INPUT	DESCRIPTION
HIGH	AT COMMAND MODE
LOW	BYPASS MODE (DATA MODE)

※ DEVICE와 연결되기 전에는 AT COMMAND MODE로 동작

※ DEVICE와 연결 후 UART MODE PIN HIGH,LOW로 UART MODE 동작 결정

FACTORY RESET



※ FACTORY_RST/PIO[9]

DEFAULT SETTING은 INPUT 설정
4초 이상 HIGH 유지시 +OK 응답 후 공장초기화 상태로 복귀시킨다.

CHIPSEN Co.,Ltd.
www.chipsen.com
매 장 : 1599-6885
사 후 설 : 1599-6005

Title: **BoT-CLE310 REF APPLICAITON**

Size: A3	Document Number: INTERNAL ANT. / UART ON / UART 5V	Rev: 1.0
----------	--	----------

Date: Wednesday, December 30, 2020 Sheet 3 of 4

BoT-CLE310 REF. APPLICATION

Example Schematic

- EXTERNAL ANTENNA
- UART always On
- UART 3.3V level input
- Bypass in Bluetooth connected state

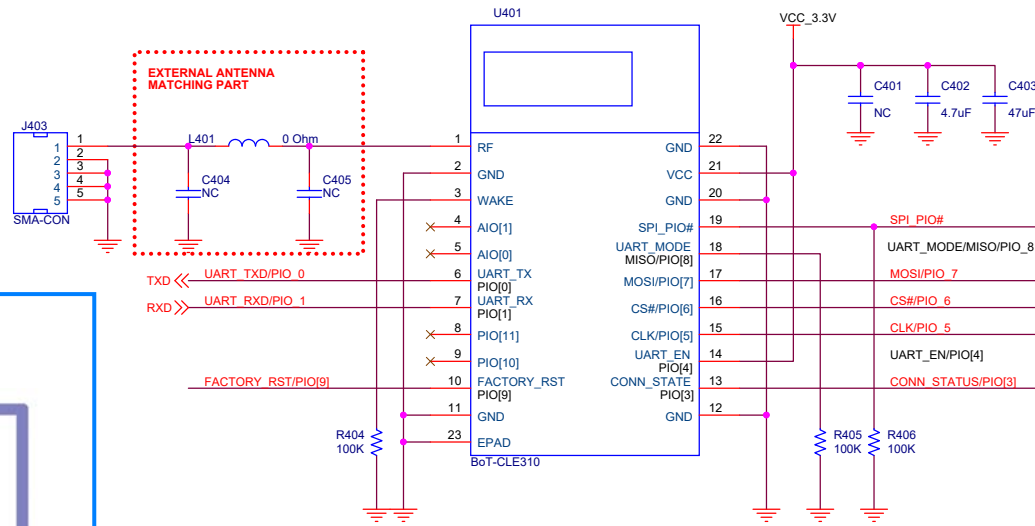

EXTERNAL ANTENNA OPTION

TEST 개별 샘플만 수납 변경

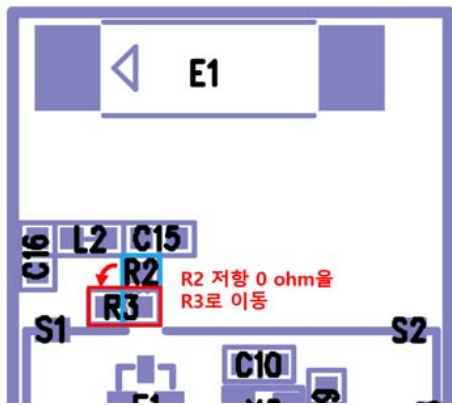

FACTORY RESET



※ FACTORY_RST/PIO[9]

DEFAULT SETTING은 INPUT 설정
4초 이상 HIGH 유지시 +OK 응답 후 공장초기화 상태로 복귀시킨다.

CONN_STATUS LED OPTION

CONNECTION STATE

OUTPUT	DESCRIPTION
HIGH	DEVICE CONNECTION
LOW	DEVICE DISCONNECTION

EXAMPLE 1

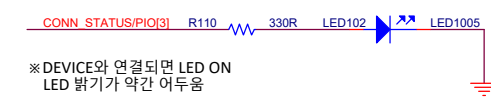

※ DEVICE와 연결되면 LED ON
LED 밝기가 약간 어두움

EXAMPLE 2

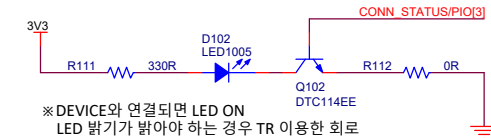

※ DEVICE와 연결되면 LED ON
LED 밝기가 밝아야 하는 경우 TR 이용한 회로

SPI PORT



SPI_PIO#

INPUT	DESCRIPTION
HIGH	PIO[8:5] SPI DEBUG SPI MODE ON
LOW	PIO[8:5] PROGRAMMABLE I/O MODE

※ F/W UPDATE 및 무선 인증 시 사용됩니다.
TP 또는 HEADER 설계 적용

UART PORT



UART EN

Example

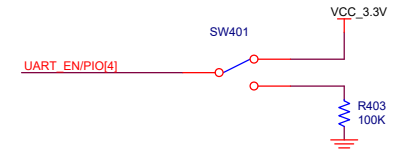

UART EN

INPUT	DESCRIPTION
HIGH	UART ENABLE
LOW	UART DISABLE

※ UART 통신을 사용하려면 무조건 UART EN PIN에 HIGH 입력해야 한다.

UART MODE

Example

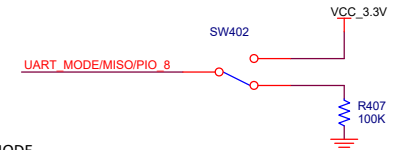

UART MODE

INPUT	DESCRIPTION
HIGH	AT COMMAND MODE
LOW	BYPASS MODE (DATA MODE)

※ DEVICE와 연결되기 전에는 AT COMMAND MODE로 동작
※ DEVICE와 연결 후 UART MODE PIN HIGH,LOW로 UART MODE 동작 결정

CHIPSEN Co.,Ltd.
www.chipsen.com
해 장 : 1599-6885
사 후 실 : 1599-6005

BoT-CLE310 REF APPLICAITON

Title: BoT-CLE310 REF APPLICAITON

Size: A3 Document Number: EXTERNAL ANT. / UART ON / UART 3.3V Rev: 1.0

Date: Wednesday, December 30, 2020 Sheet: 4 of 4